

Green Hill Solar Farm

EN010170

Environmental Statement

Appendix 8.1: LVIA Methodology

Revision B

(Part 2 of 2)

Prepared by: Lanpro Services

Date: March 2026

Document Reference: EX6/GH6.3.8.1_B

APFP Regulation 5(2)(a)



Schedule of Changes

| Revision | Section Reference | Description of Changes | Reason for Revision |
|----------|--|---|---|
| A | Photography and Photomontage Methodology | Addition of viewpoints MKCC 1, MKCC 2, and MKCC 3 | As requested by Milton Keynes City Council. |
| B | Photography and Photomontage Methodology | Addition of photomontage for viewpoint VP51 | As requested within the ExA Third Written Questions |

APPENDIX 1.2: LAYOUT INFORMATION USED FOR 3D MODEL CONSTRUCTION

Key

- Area For Solar Panels And Associated Development
- Existing
 - Existing Vegetation
 - Existing Ditch Verge
 - Existing Footpath
 - Existing Bridleway
 - Existing Byway Open To All Traffic
 - Existing Restricted Byways
 - Existing Buildings
 - Existing Listed Buildings
 - Existing Utilities
- Proposed
 - Existing Vegetation To Be Retained And Enhanced
 - Proposed Meadow Creation (Beneath Panels)
 - Proposed Tussock Grassland Margins
 - Proposed Damp Grassland
 - Proposed Ground Nesting Bird Mitigation - Set Aside
 - Proposed Ground Nesting Bird Mitigation - Continued Arable Land
 - Proposed Diverse Wildflower Meadow
 - Proposed Low Density Scrub
 - Proposed Native Woodland Coppice/Shelter Belt (Scrub And Tree Planting)
 - Dense Linear Tree Planting (Without Scrub Planting)
 - Native Tree and Scrub Planting - Instant Screening
 - Native Scrub Planting With Scattered Trees
 - Proposed River Corridor Planting For Ecology
 - Proposed River Corridor Planting For Flooding
 - Proposed River Corridor Planting For Instant Screening
 - Proposed Indicative Locations For Ponds
 - Potential Location For Proposed Cluster Of Wader Scrapes
 - Existing Hedge To Be Reinforced With Irregularly Spaced Native Tree Planting
 - Existing Hedge To Be Reinforced With Densely Spaced Native Tree Planting - Instant Screening
 - Existing Hedge To Be Reinforced With Densely Spaced Native Tree Planting - Instant Screening
 - Proposed Native Species Rich Hedgerow With Irregularly Spaced Native Hedgerow Trees
 - Proposed Secondary Native Species Rich Hedgerow With Densely Spaced Native Hedgerow Trees
 - Proposed Solar Arrays
 - Proposed Fencing
 - Proposed Access Tracks
 - Proposed Inverters
 - Proposed Substation
 - Proposed Battery Energy Storage Systems
 - Proposed Permissive Path For Pedestrians
 - Proposed Permissive Path For Pedestrians And Horse Riders
 - Existing Vegetation To Be Removed

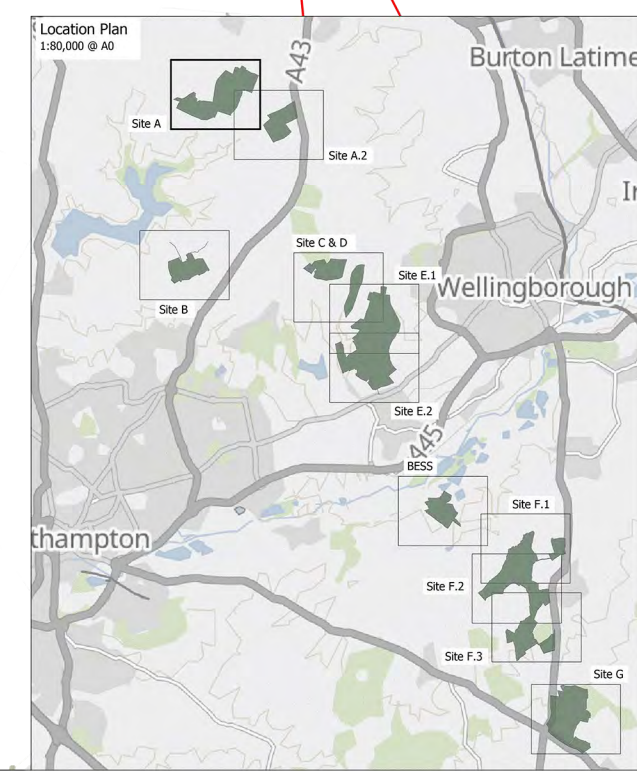
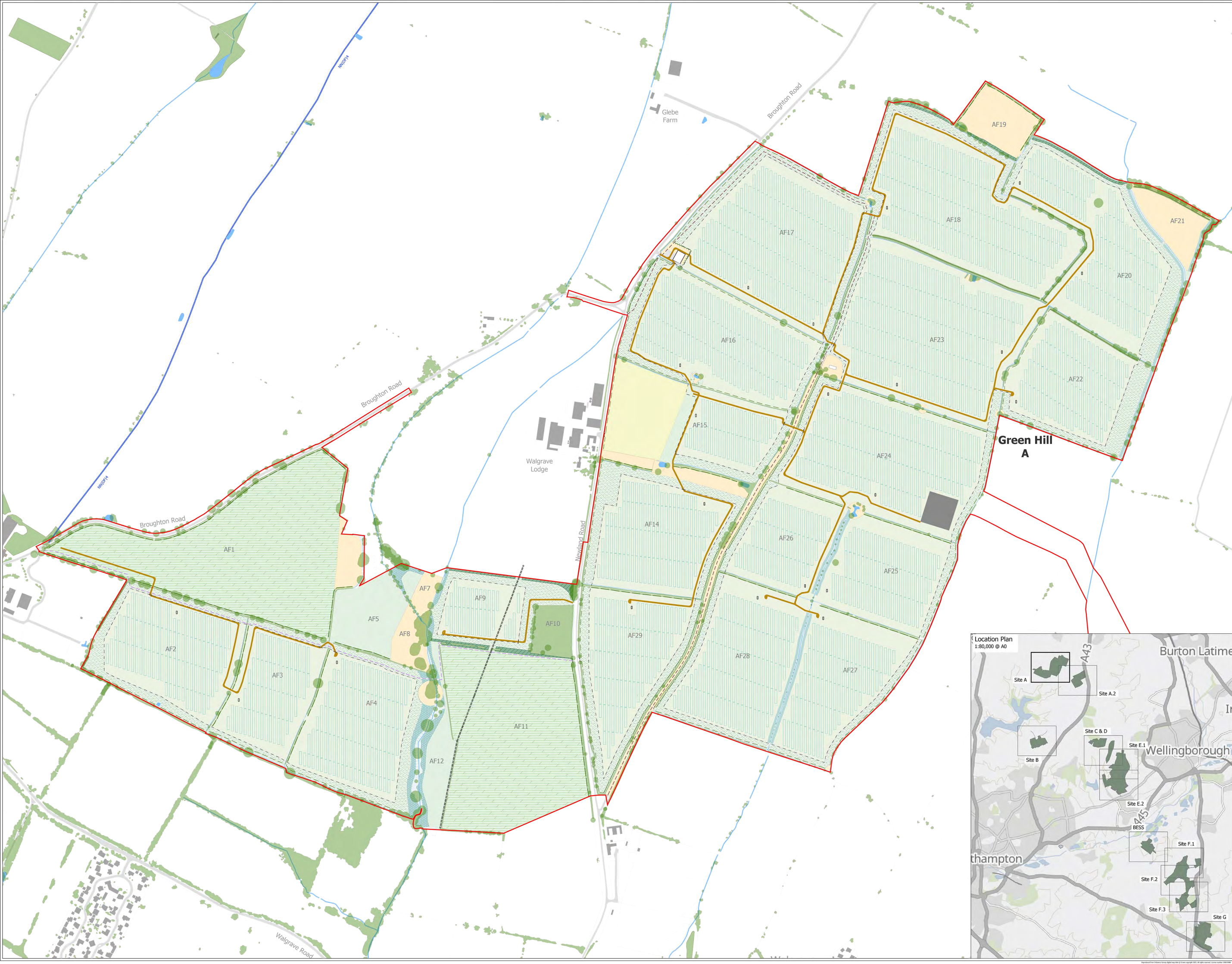

GREEN HILL SOLAR FARM
 Figure 4.10
 Green Hill Site A
 Landscape and Ecology Mitigation Plan
 [ENR10170/APY/GH-4.4.10]
 5/2(a)

Key

| | |
|-----------------|--|
| | Area For Solar Panels And Associated Development |
| Existing | |
| | Existing Vegetation |
| | Existing Ditch Verge |
| | Existing Footpath |
| | Existing Driveway |
| | Existing Byway Open To All Traffic |
| | Existing Restricted Byways |
| | Existing Buildings |
| | Existing Listed Buildings |
| | Existing Utilities |
| Proposed | |
| | Existing Vegetation To Be Retained And Enhanced |
| | Proposed Meadow Creation (Beneath Panels) |
| | Proposed Tussock Grassland Margins |
| | Proposed Damp Grassland |
| | Proposed Ground Nesting Bird Mitigation - Set Aside |
| | Proposed Ground Nesting Bird Mitigation - Continued Arable Land |
| | Proposed Diverse Wildflower Meadow |
| | Proposed Low Density Scrub |
| | Proposed Native Woodland Copse/Shelter Belt (Scrub And Tree Planting) |
| | Dense Linear Tree Planting (Without Scrub Planting) |
| | Native Tree and Scrub Planting - Instant Screening |
| | Native Scrub Planting With Scattered Trees |
| | Proposed River Corridor Planting For Ecology |
| | Proposed River Corridor Planting For Flooding |
| | Proposed River Corridor Planting For Instant Screening |
| | Proposed Indicative locations For Ponds |
| | Potential Location For Proposed Cluster Of Water Scrapes |
| | Existing Hedge To Be Reinforced With Irregularly Spaced Native Tree Planting |
| | Existing Hedge To Be Reinforced With Densely Spaced Native Tree Planting - Instant Screening |
| | Existing Hedge To Be Reinforced With Densely Spaced Native Tree Planting - Instant Screening |
| | Proposed Native Species Rich Hedgerow With Irregularly Spaced Native Hedgerow Trees |
| | Proposed Secondary Native Species Rich Hedgerow With Densely Spaced Native Hedgerow Trees |
| | Proposed Solar Arrays |
| | Proposed Fenceline |
| | Proposed Access Tracks |
| | Proposed Inverters |
| | Proposed Substation |
| | Proposed Battery Energy Storage Systems |
| | Proposed Permissive Path For Pedestrians |
| | Proposed Permissive Path For Pedestrians And Horse Riders |
| | Existing Vegetation To Be Removed |

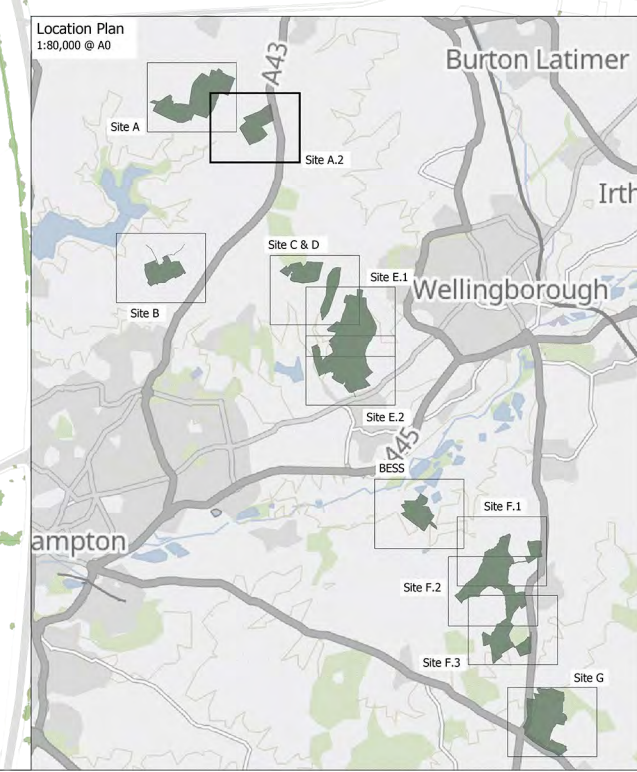
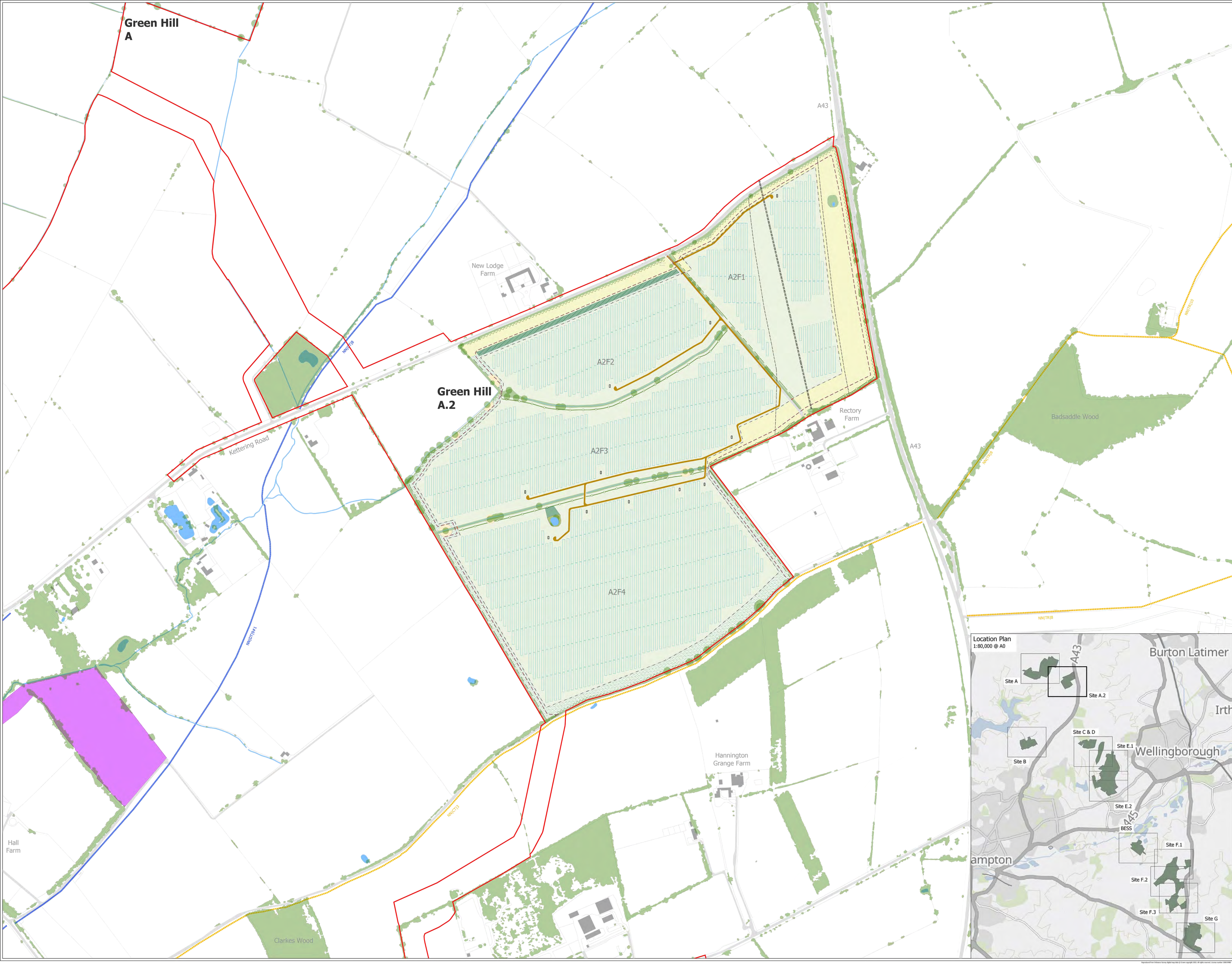

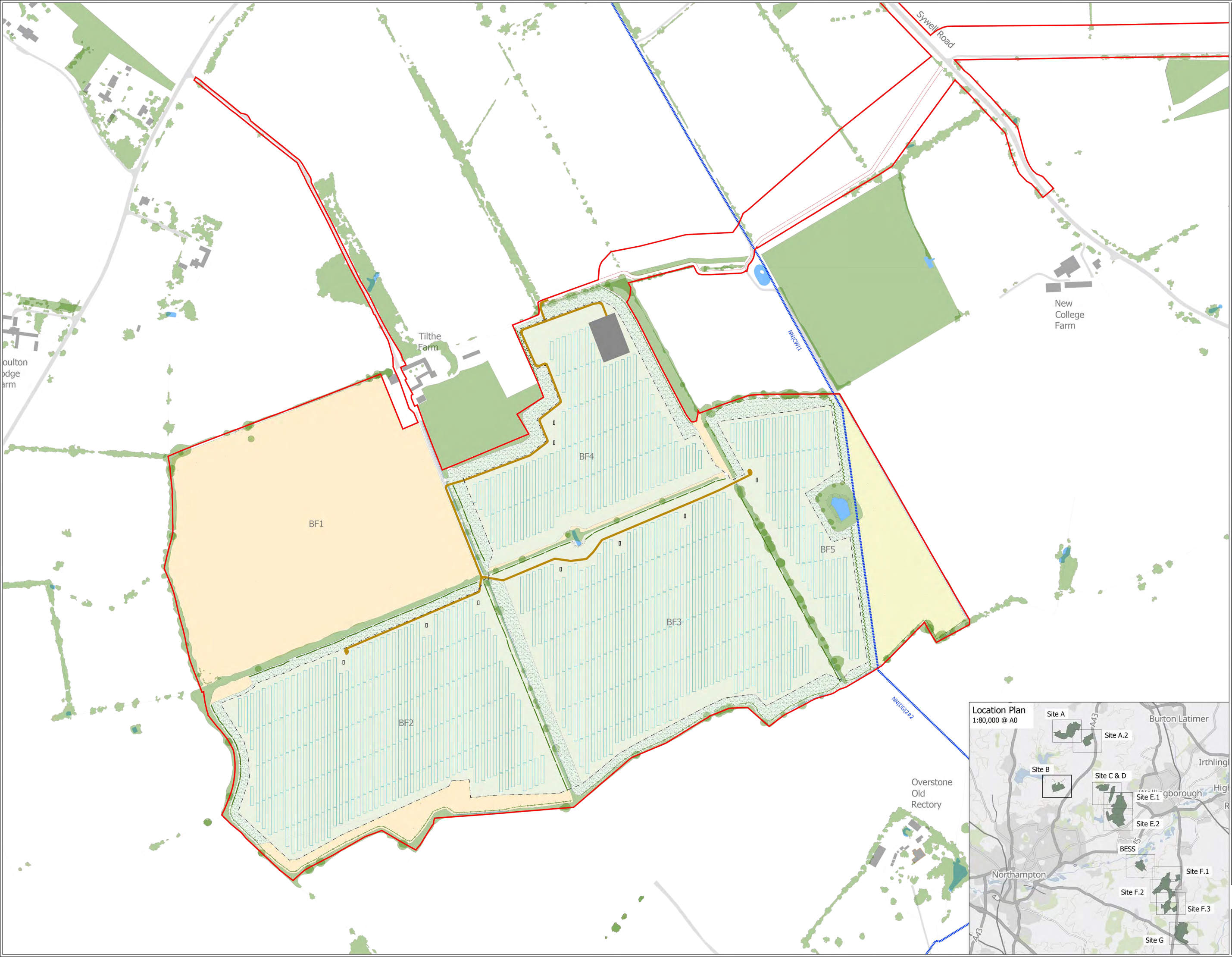

- Area For Solar Panels And Associated Development
- Existing
 - Existing Vegetation
 - Existing Open Water
 - Existing Footpath
 - Existing Bridleway
 - Existing Bwy Open To All Traffic
 - Existing Restricted Bwy
 - Existing Buildings
 - Existing Listed Buildings
 - Existing Utilities
- Proposed
 - Existing Vegetation To Be Retained And Enhanced
 - Proposed Meadow Creation (Beneath Panels)
 - Proposed Tussock Grassland Margins
 - Proposed Damp Grassland
 - Proposed Ground Nesting Bird Mitigation - Set Aids
 - Proposed Ground Nesting Bird Mitigation - Continual Arable Land
 - Proposed Diverse Wildflower Meadow
 - Proposed Low Density Scrub
 - Proposed Native Woodland Copse/Shrub Belt (Scrub And Tree Planting)
 - Dense Linear Tree Planting (Without Scrub Planting)
 - Native Tree and Scrub Planting - Instant Screening
 - Native Scrub Planting With Scattered Trees
 - Proposed River Corridor Planting For Ecology
 - Proposed River Corridor Planting For Flooding
 - Proposed River Corridor Planting For Instant Screening
 - Proposed Indicative Locations For Ponds
 - Potential Location For Proposed Cluster Of Water Scrapes
 - Existing Hedge To Be Reinforced With Irregularly Spaced Native Tree Planting
 - Existing Hedge To Be Reinforced With Densely Spaced Native Tree Planting
 - Existing Hedge To Be Reinforced With Densely Spaced Native Tree Planting - Instant Screening
 - Proposed Native Species Rich Hedgerow With Irregularly Spaced Native Hedgerow Trees
 - Proposed Secondary Native Species Rich Hedgerow With Densely Spaced Native Hedgerow Trees
 - Proposed Solar Arrays
 - Proposed Fenceline
 - Proposed Access Tracks
 - Proposed Driveways
 - Proposed Substation
 - Proposed Battery Energy Storage Systems
 - Proposed Permissive Path For Pedestrians
 - Proposed Permissive Path For Pedestrians And Horse Riders
 - Existing Vegetation To Be Removed

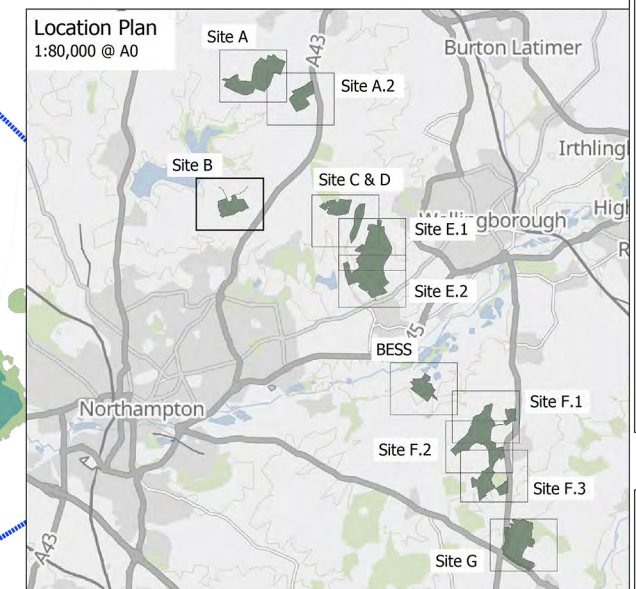

Key

| | |
|-----------------|--|
| | Area For Solar Panels And Associated Development |
| Existing | |
| | Existing Vegetation |
| | Existing Ditch Verge |
| | Existing Footpath |
| | Existing Brideway |
| | Existing Byway Open To All Traffic |
| | Existing Restricted Byways |
| | Existing Buildings |
| | Existing Listed Buildings |
| | Existing Utilities |
| Proposed | |
| | Existing Vegetation To Be Retained And Enhanced |
| | Proposed Meadow Creation (Beneath Panels) |
| | Proposed Tussock Grassland Margins |
| | Proposed Damp Grassland |
| | Proposed Ground Nesting Bird Mitigation - Set Aside |
| | Proposed Ground Nesting Bird Mitigation - Continued Arable Land |
| | Proposed Diverse Willowher Meadow |
| | Proposed Low Density Scrub |
| | Proposed Native Woodland Copse/Shelter Belt (Scrub And Tree Planting) |
| | Dense Linear Tree Planting (Without Scrub Planting) |
| | Native Tree and Scrub Planting - Instant Screening |
| | Native Scrub Planting With Scattered Trees |
| | Proposed River Corridor Planting For Ecology |
| | Proposed River Corridor Planting For Flooding |
| | Proposed River Corridor Planting For Instant Screening |
| | Proposed Indicative Locations For Ponds |
| | Potential Location For Proposed Cluster Of Water Scrapes |
| | Existing Hedge To Be Reinforced With Irregularly Spaced Native Tree Planting |
| | Existing Hedge To Be Reinforced With Densely Spaced Native Tree Planting |
| | Existing Hedge To Be Reinforced With Densely Spaced Native Tree Planting - Instant Screening |
| | Proposed Native Species Rich Hedgerow With Irregular Spaced Native Hedgerow Trees |
| | Proposed Secondary Native Species Rich Hedgerow With Densely Spaced Native Hedgerow Trees |
| | Proposed Solar Arrays |
| | Proposed Fenceline |
| | Proposed Access Tracks |
| | Proposed Inverters |
| | Proposed Substation |
| | Proposed Battery Energy Storage Systems |
| | Proposed Permissive Path For Pedestrians |
| | Proposed Permissive Path For Pedestrians and Horse Riders |
| | Proposed Private Access To Sywell Wood |
| | Existing Vegetation To Be Removed |

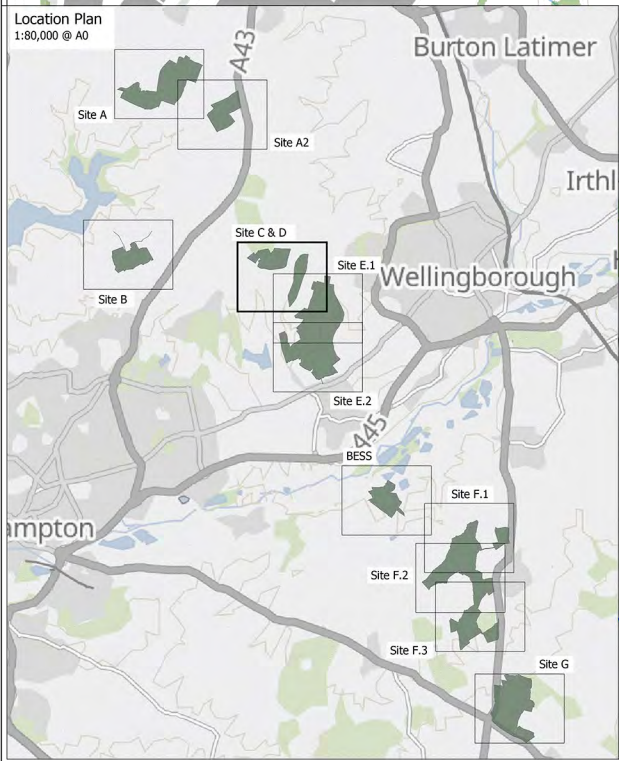
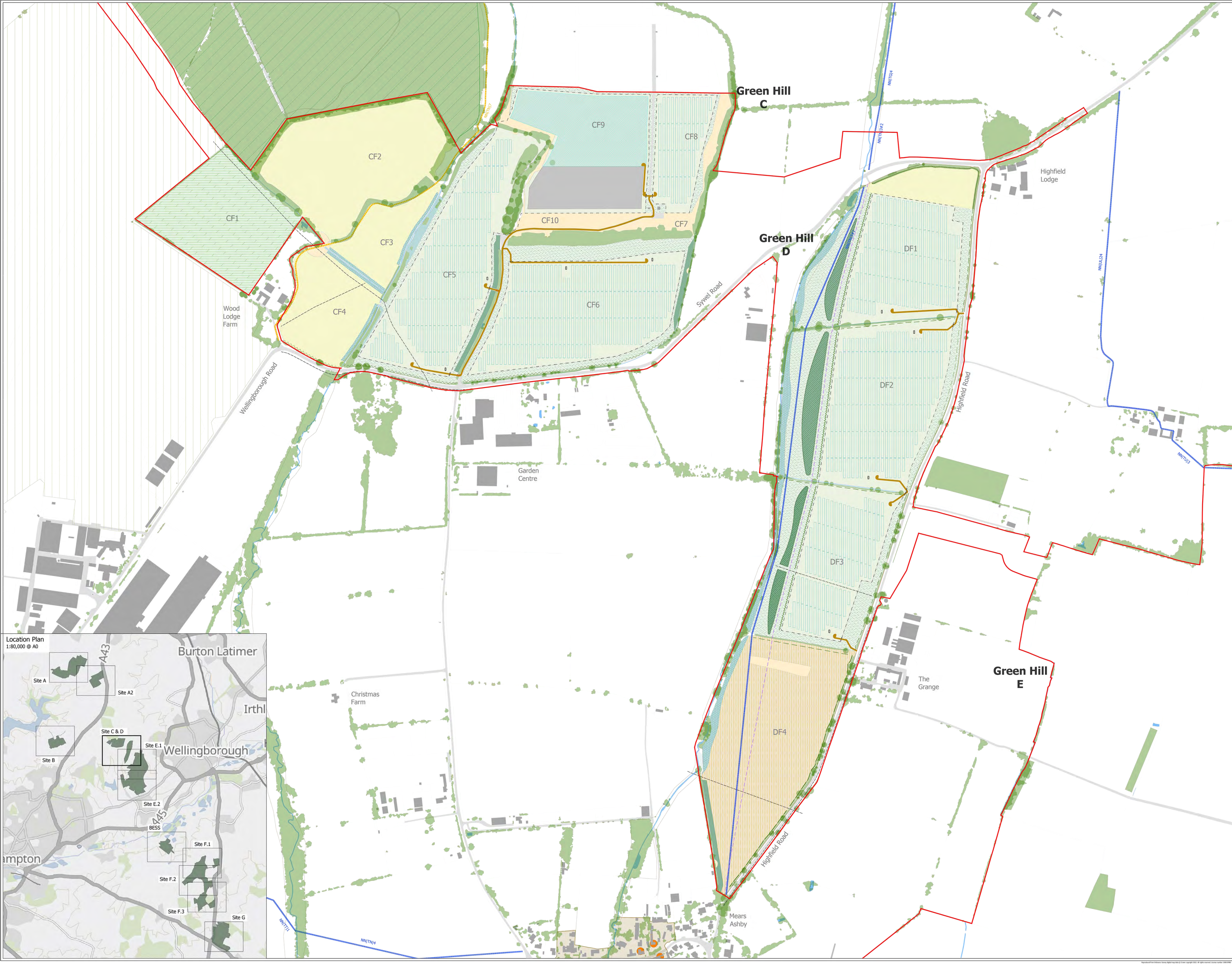

Key

- Area For Solar Panels And Associated Development
- Existing
 - Existing Vegetation
 - Existing Ditch Verge
 - Existing Footpath
 - Existing Bridleway
 - Existing Byway Open To All Traffic
 - Existing Restricted Byways
 - Existing Buildings
 - Existing Listed Buildings
 - Existing Utilities
- Proposed
 - Existing Vegetation To Be Retained And Enhanced
 - Proposed Meadow Creation (Beneath Panels)
 - Proposed Tussock Grassland Margins
 - Proposed Cuckoo Grassland
 - Proposed Ground Nesting Bird Mitigation - Set Aside
 - Proposed Ground Nesting Bird Mitigation - Continued Arable Land
 - Proposed Diverse Wildflower Meadow
 - Proposed Low Density Scrub
 - Proposed Native Woodland Coppice/Shelter Belt (Scrub And Tree Planting)
 - Dense Linear Tree Planting (Without Scrub Planting)
 - Native Tree and Scrub Planting - Instant Screening
 - Native Scrub Planting With Scattered Trees
 - Proposed River Corridor Planting For Ecology
 - Proposed River Corridor Planting For Flooding
 - Proposed River Corridor Planting For Instant Screening
 - Proposed Indicative Locations For Ponds
 - Potential Location For Proposed Cluster Of Water Scapes
 - Existing Hedge To Be Reinforced With Irregularly Spaced Native Tree Planting
 - Existing Hedge To Be Reinforced With Densely Spaced Native Tree Planting
 - Existing Hedge To Be Reinforced With Densely Spaced Native Tree Planting - Instant Screening
 - Proposed Native Species Rich Hedgerow With Irregularly Spaced Native Hedgerow Trees
 - Proposed Secondary Native Species Rich Hedgerow With Densely Spaced Native Hedgerow Trees
 - Proposed Solar Arrays
 - Proposed Fenceline
 - Proposed Access Tracks
 - Proposed Inverters
 - Proposed Substation
 - Proposed Battery Energy Storage Systems
 - Proposed Permissive Path For Pedestrians
 - Proposed Permissive Path For Pedestrians And Horse Riders
 - Existing Vegetation To Be Removed

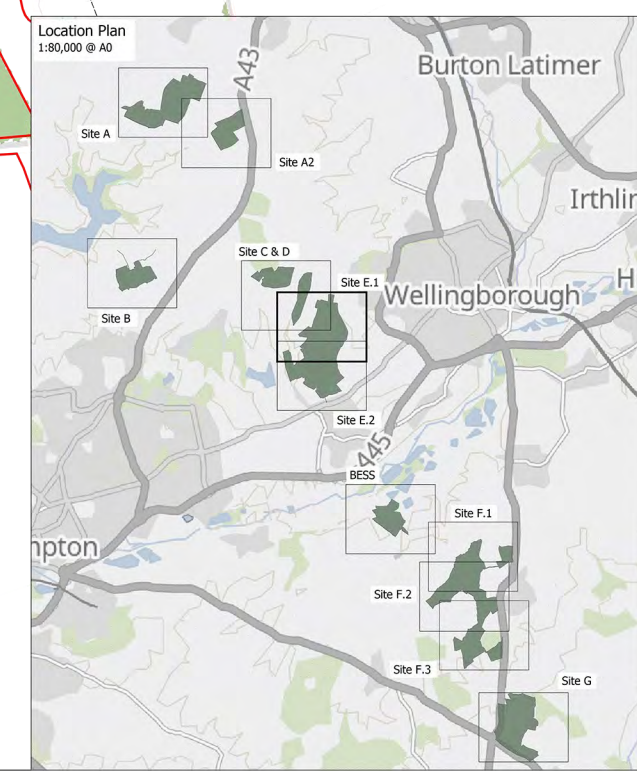
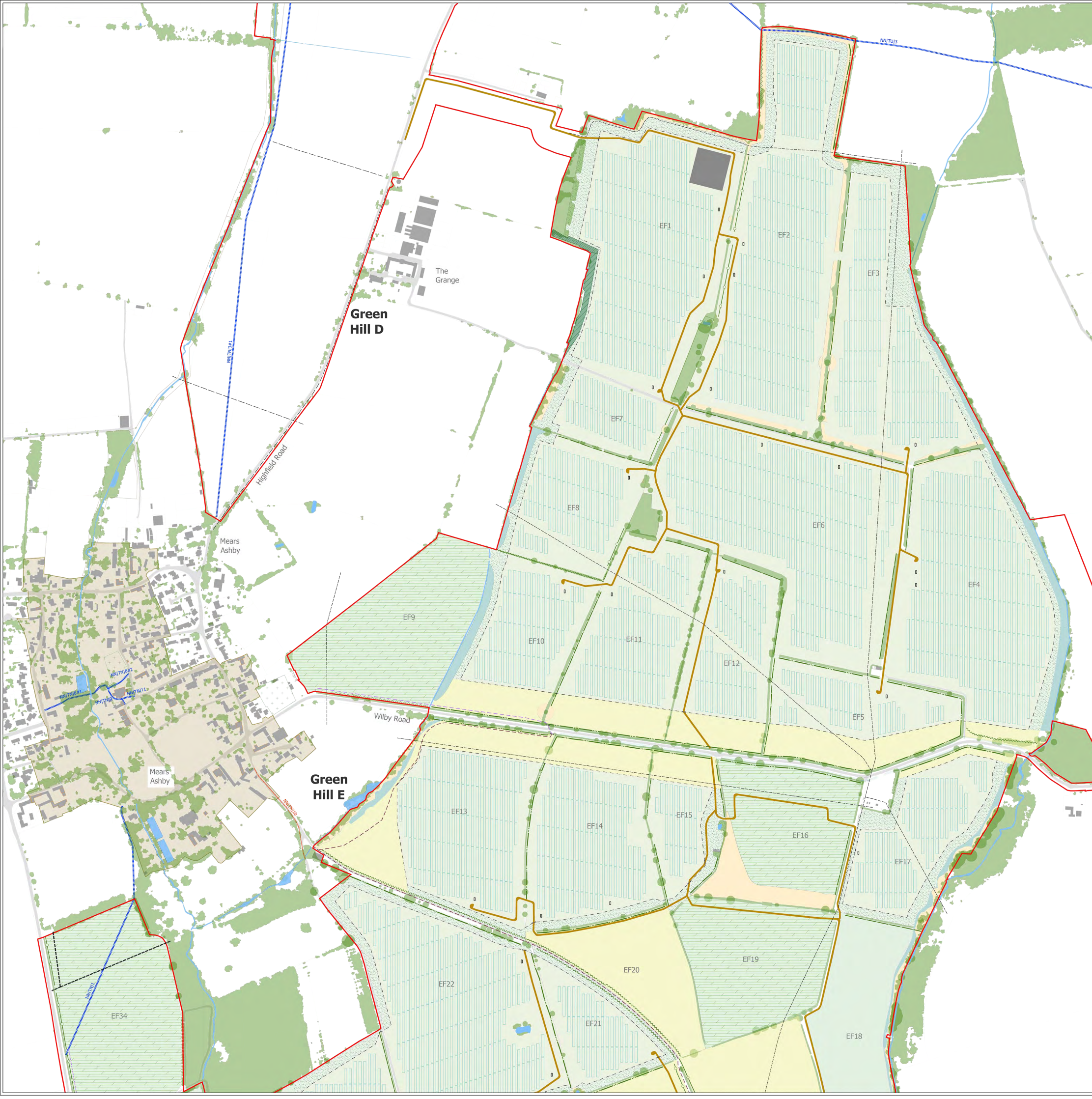

Key

- Area For Solar Panels And Associated Development
- Existing
 - Existing Vegetation
 - Existing Ditch Verge
 - Existing Footpath
 - Existing Bridleway
 - Existing Byway Open To All Traffic
 - Existing Restricted Byways
 - Existing Buildings
 - Existing Listed Buildings
 - Existing Utilities
- Proposed
 - Existing Vegetation To Be Retained And Enhanced
 - Proposed Meadow Creation (Beneath Panels)
 - Proposed Tussock Grassland Margins
 - Proposed Damp Grassland
 - Proposed Ground Nesting Bird Mitigation - Set Aside
 - Proposed Ground Nesting Bird Mitigation - Continued Arable Land
 - Proposed Diverse Wildflower Meadow
 - Proposed Low Density Scrub
 - Proposed Native Woodland Coppice/Shelter Belt (Scrub And Tree Planting)
 - Dense Linear Tree Planting (Without Scrub Planting)
 - Native Tree and Scrub Planting - Instant Screening
 - Native Scrub Planting With Scattered Trees
 - Proposed River Corridor Planting For Ecology
 - Proposed River Corridor Planting For Flooding
 - Proposed River Corridor Planting For Instant Screening
 - Proposed Indicative Locations For Ponds
 - Potential Location For Proposed Cluster Of Water Scapes
 - Existing Hedge To Be Reinforced With Irregularly Spaced Native Tree Planting
 - Existing Hedge To Be Reinforced With Densely Spaced Native Tree Planting
 - Existing Hedge To Be Reinforced With Densely Spaced Native Tree Planting - Instant Screening
 - Proposed Native Species Rich Hedgerow With Irregularly Spaced Native Hedgerow Trees
 - Proposed Secondary Native Species Rich Hedgerow With Densely Spaced Native Hedgerow Trees
 - Proposed Solar Arrays
 - Proposed Fenceline
 - Proposed Access Tracks
 - Proposed Inverters
 - Proposed Substation
 - Proposed Battery Energy Storage Systems
 - Proposed Permissive Path For Pedestrians
 - Proposed Permissive Path For Pedestrians And Horse Riders
 - Existing Vegetation To Be Removed

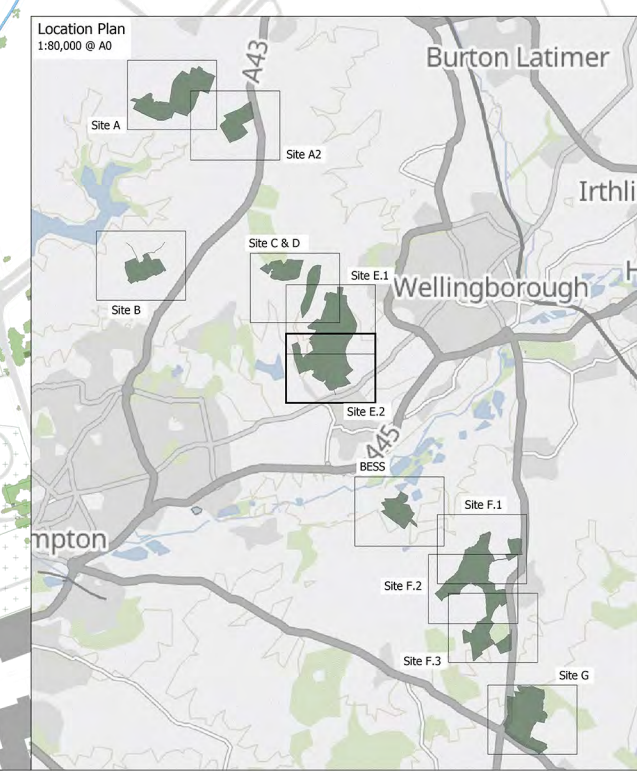
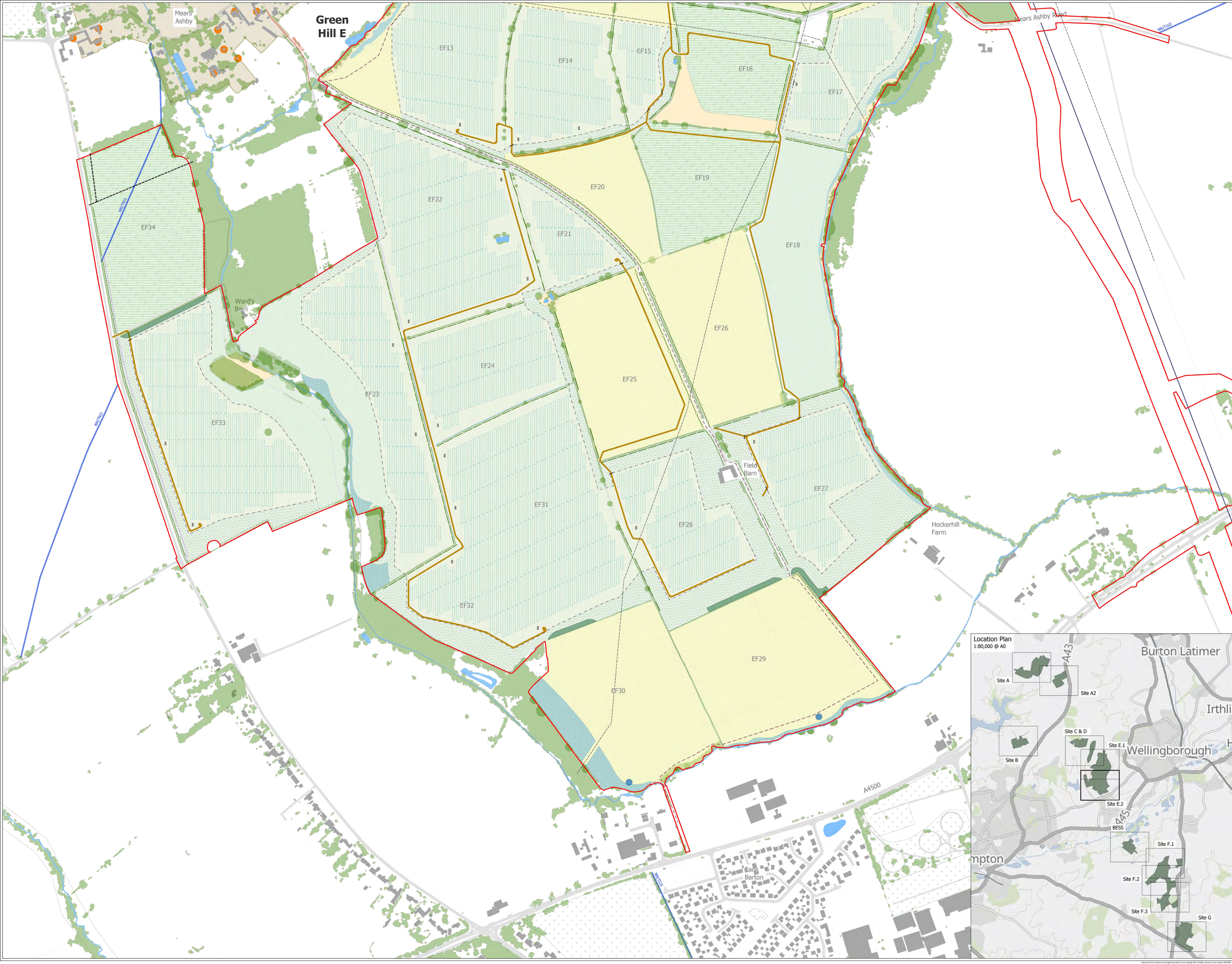

Key

- Area For Solar Panels And Associated Development
- Existing
 - Existing Vegetation
 - Existing Ditch Verge
 - Existing Footpath
 - Existing Bridleway
 - Existing Byway Open To All Traffic
 - Existing Restricted Byways
 - Existing Buildings
 - Existing Listed Buildings
 - Existing Utilities
- Proposed
 - Existing Vegetation To Be Retained And Enhanced
 - Proposed Meadow Creation (Beneath Panels)
 - Proposed Tussock Grassland Margins
 - Proposed Damp Grassland
 - Proposed Ground Nesting Bird Mitigation - Set Aside
 - Proposed Ground Nesting Bird Mitigation - Continued Arable Land
 - Proposed Diverse Wildflower Meadow
 - Proposed Low Density Scrub
 - Proposed Native Woodland Coppice/Shelter Belt (Scrub And Tree Planting)
 - Dense Linear Tree Planting (Without Scrub Planting)
 - Native Tree and Scrub Planting - Instant Screening
 - Native Scrub Planting With Scattered Trees
 - Proposed River Corridor Planting For Ecology
 - Proposed River Corridor Planting For Flooding
 - Proposed River Corridor Planting For Instant Screening
 - Proposed Indicative locations For Ponds
 - Potential Location For Proposed Cluster Of Water Scrapes
 - Existing Hedge To Be Reinforced With Irregularly Spaced Native Tree Planting
 - Existing Hedge To Be Reinforced With Densely Spaced Native Tree Planting
 - Existing Hedge To Be Reinforced With Densely Spaced Native Tree Planting - Instant Screening
 - Proposed Native Species Rich Hedgerow With Irregular Spaced Native Hedgerow Trees
 - Proposed Secondary Native Species Rich Hedgerow With Densely Spaced Native Hedgerow Trees
 - Proposed Solar Arrays
 - Proposed Fenceline
 - Proposed Access Tracks
 - Proposed Inverters
 - Proposed Substation
 - Proposed Battery Energy Storage Systems
 - Proposed Permissive Path For Pedestrians
 - Proposed Permissive Path For Pedestrians And Horse Riders
 - Existing Vegetation To Be Removed

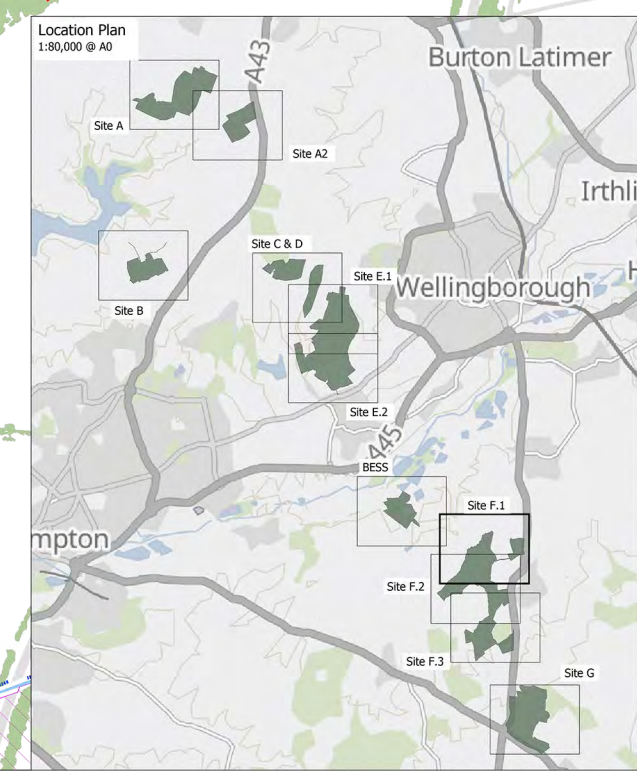
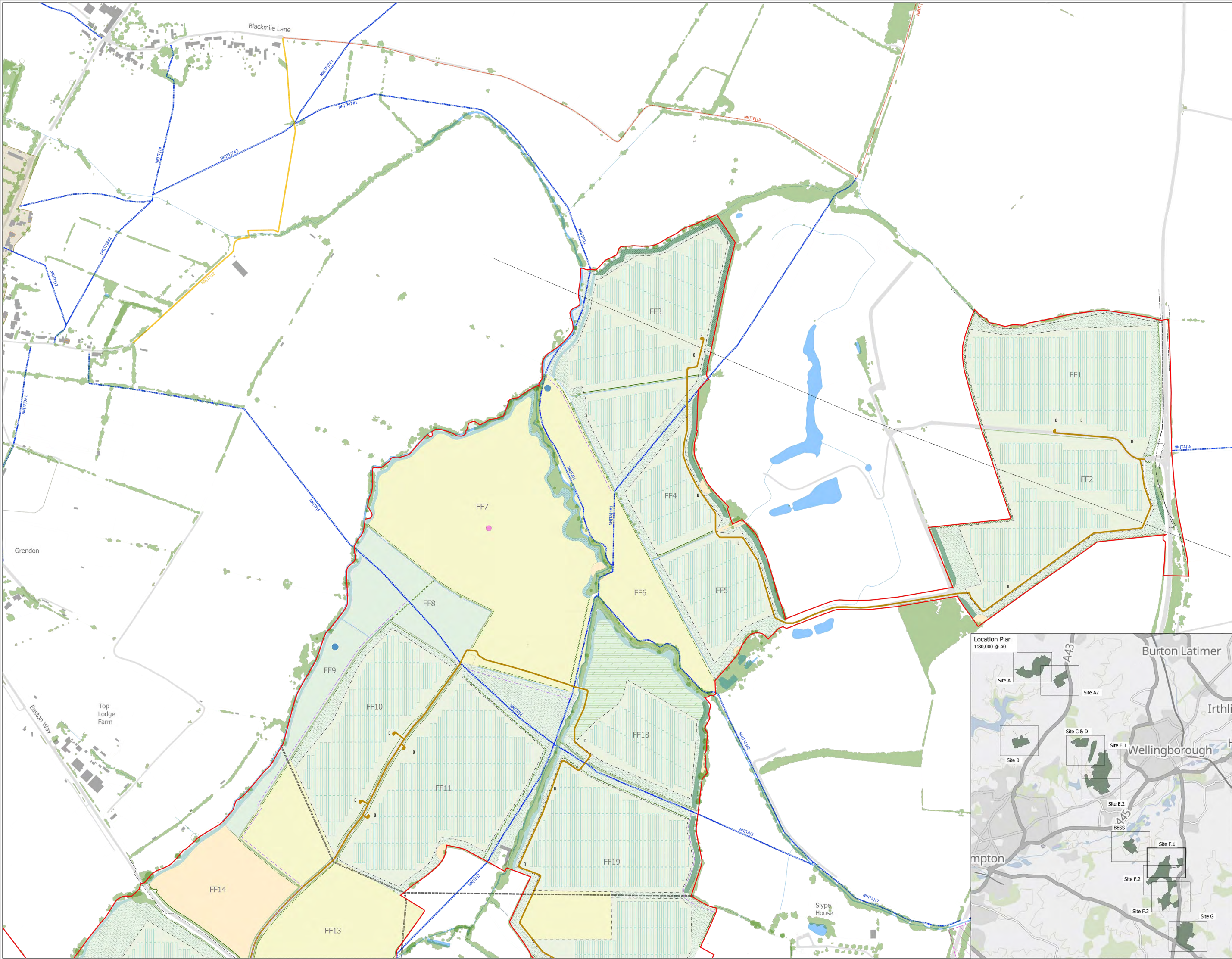

Key

| | |
|--|--|
| | Area For Solar Panels And Associated Development |
| | Existing Vegetation |
| | Existing Ditch Verge |
| | Existing Footpath |
| | Existing Brideway |
| | Existing Byway Open To All Traffic |
| | Existing Restricted Byways |
| | Existing Buildings |
| | Existing Listed Buildings |
| | Existing Utilities |
| | Proposed Existing Vegetation To Be Retained And Enhanced |
| | Proposed Meadow Creation (Beneath Panels) |
| | Proposed Tussock Grassland Margins |
| | Proposed Damp Grassland |
| | Proposed Ground Nesting Bird Mitigation - Set Aside |
| | Proposed Ground Nesting Bird Mitigation - Continued Arable Land |
| | Proposed Diverse Wildflower Meadow |
| | Proposed Low Density Scrub |
| | Proposed Native Woodland Copse/Shelter Belt (Scrub And Tree Planting) |
| | Dense Linear Tree Planting (Without Scrub Planting) |
| | Native Tree and Scrub Planting - Instant Screening |
| | Native Scrub Planting With Scattered Trees |
| | Proposed River Corridor Planting For Ecology |
| | Proposed River Corridor Planting For Flooding |
| | Proposed River Corridor Planting For Instant Screening |
| | Proposed Indicative Locations For Ponds |
| | Potential Location For Proposed Cluster Of Water Scrapes |
| | Existing Hedge To Be Reinforced With Irregularly Spaced Native Tree Planting |
| | Existing Hedge To Be Reinforced With Densely Spaced Native Tree Planting |
| | Existing Hedge To Be Reinforced With Densely Spaced Native Tree Planting - Instant Screening |
| | Proposed Native Species Rich Hedgerow With Irregularly Spaced Native Hedgerow Trees |
| | Proposed Secondary Native Species Rich Hedgerow With Densely Spaced Native Hedgerow Trees |
| | Proposed Solar Arrays |
| | Proposed Fencing |
| | Proposed Access Tracks |
| | Proposed Inverters |
| | Proposed Substation |
| | Proposed Battery Energy Storage Systems |
| | Proposed Permissive Path For Pedestrians |
| | Proposed Permissive Path For Pedestrians And Horse Riders |
| | Existing Vegetation To Be Removed |

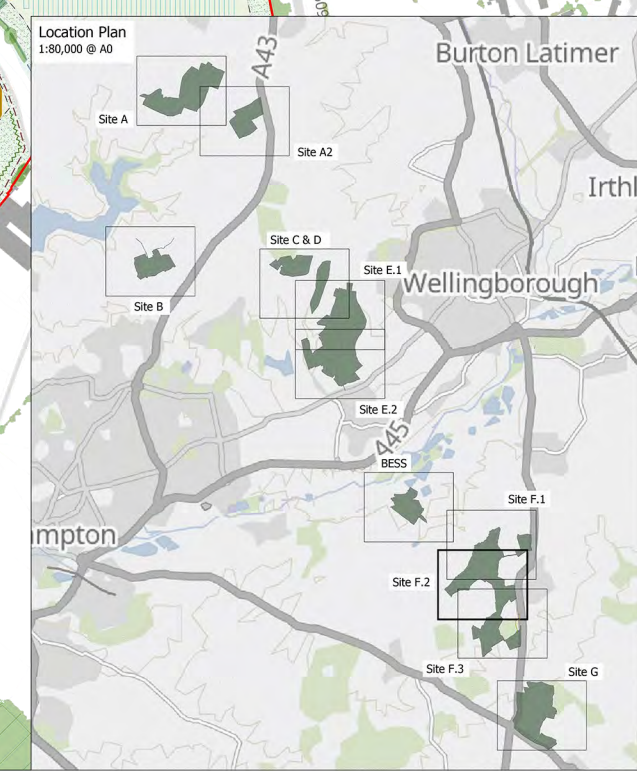
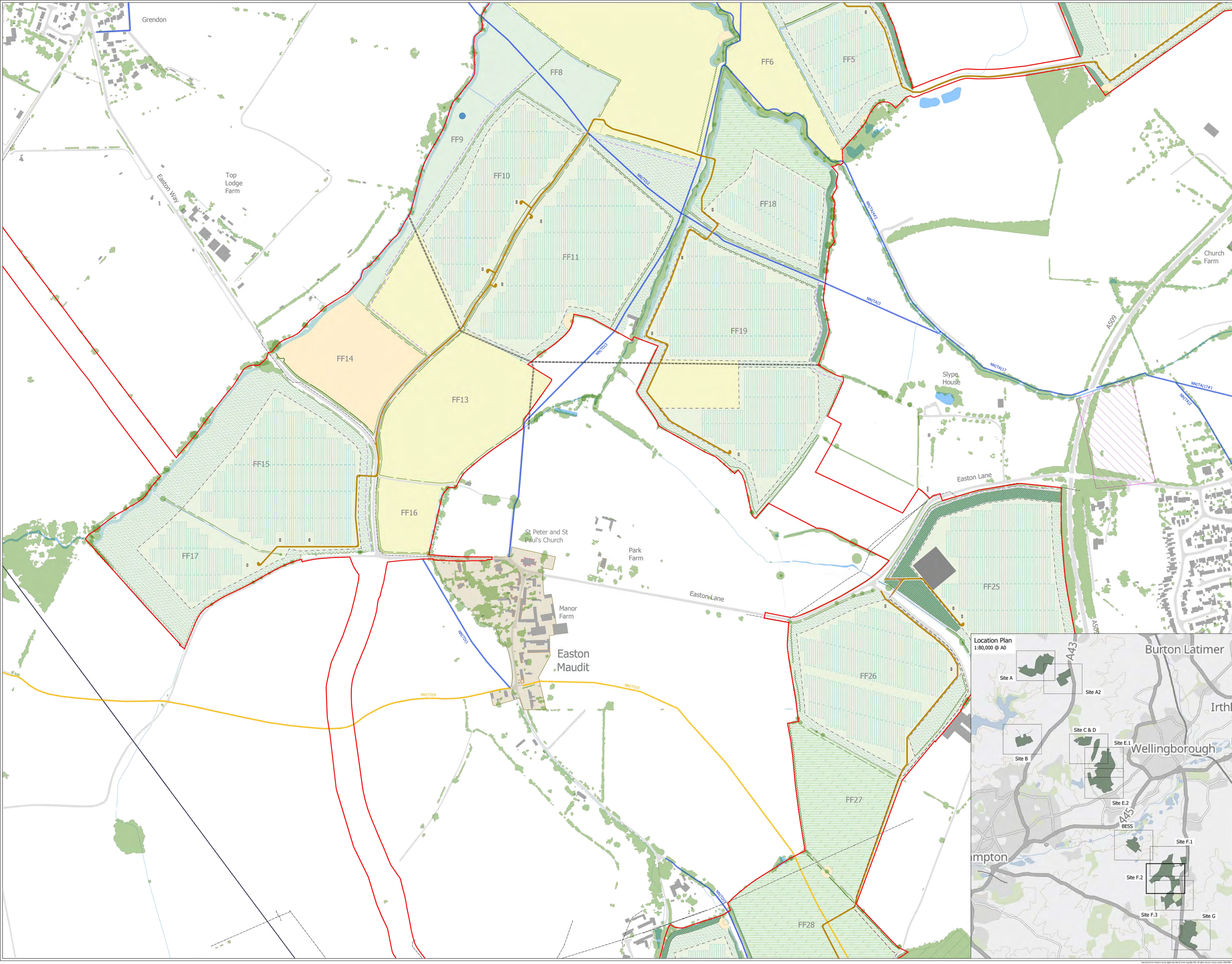

Key

| | |
|----------------------|--|
| [Red outline] | Area For Solar Panels And Associated Development |
| [Green] | Existing Vegetation |
| [Light Green] | Existing Ditch Verge |
| [Blue line] | Existing Footpath |
| [Yellow dashed line] | Existing Bridleway |
| [Orange dashed line] | Existing Byway Open To All Traffic |
| [Purple dashed line] | Existing Restricted Byways |
| [Grey square] | Existing Buildings |
| [Dark Grey square] | Existing Listed Buildings |
| [Dashed line] | Existing Utilities |
| [Orange square] | Existing Vegetation To Be Retained And Enhanced |
| [Light Green square] | Proposed Meadow Creation (Beneath Panels) |
| [Green square] | Proposed Tussock Grassland Margins |
| [Light Green square] | Proposed Damp Grassland |
| [Green square] | Proposed Ground Nesting Bird Mitigation - Set Aside |
| [Green square] | Proposed Ground Nesting Bird Mitigation - Continued Arable Land |
| [Yellow square] | Proposed Diverse Wildflower Meadow |
| [Light Green square] | Proposed Low Density Scrub |
| [Green square] | Proposed Native Woodland Copps/Shelter Belt (Scrub And Tree Planting) |
| [Green square] | Dense Linear Tree Planting (Without Scrub Planting) |
| [Green square] | Native Tree and Scrub Planting - Instant Screening |
| [Green square] | Native Scrub Planting With Scattered Trees |
| [Green square] | Proposed River Corridor Planting For Ecology |
| [Green square] | Proposed River Corridor Planting For Flooding |
| [Green square] | Proposed River Corridor Planting For Instant Screening |
| [Blue circle] | Proposed Indicative locations For Ponds |
| [Pink circle] | Potential Location For Proposed Cluster Of Water Scrapes |
| [Green line] | Existing Hedge To Be Reinforced With Irregularly Spaced Native Tree Planting |
| [Green line] | Existing Hedge To Be Reinforced With Densely Spaced Native Tree Planting |
| [Green line] | Existing Hedge To Be Reinforced With Densely Spaced Native Tree Planting - Instant Screening |
| [Green line] | Proposed Native Species Rich Hedgerow With Irregular Spaced Native Hedgerow Trees |
| [Green line] | Proposed Secondary Native Species Rich Hedgerow With Densely Spaced Native Hedgerow Trees |
| [Blue square] | Proposed Solar Arrays |
| [Dashed line] | Proposed Fencing |
| [Brown line] | Proposed Access Tracks |
| [Square] | Proposed Inverters |
| [Square] | Proposed Substation |
| [Square] | Proposed Battery Energy Storage Systems |
| [Dashed line] | Proposed Permissive Path For Pedestrians |
| [Dashed line] | Proposed Permissive Path For Pedestrians And Horse Riders |
| [Red outline] | Existing Vegetation To Be Removed |

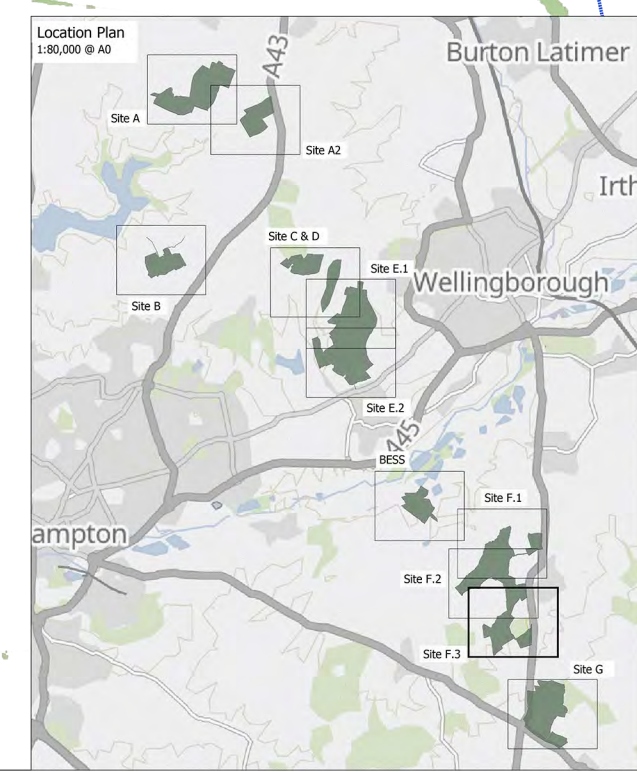
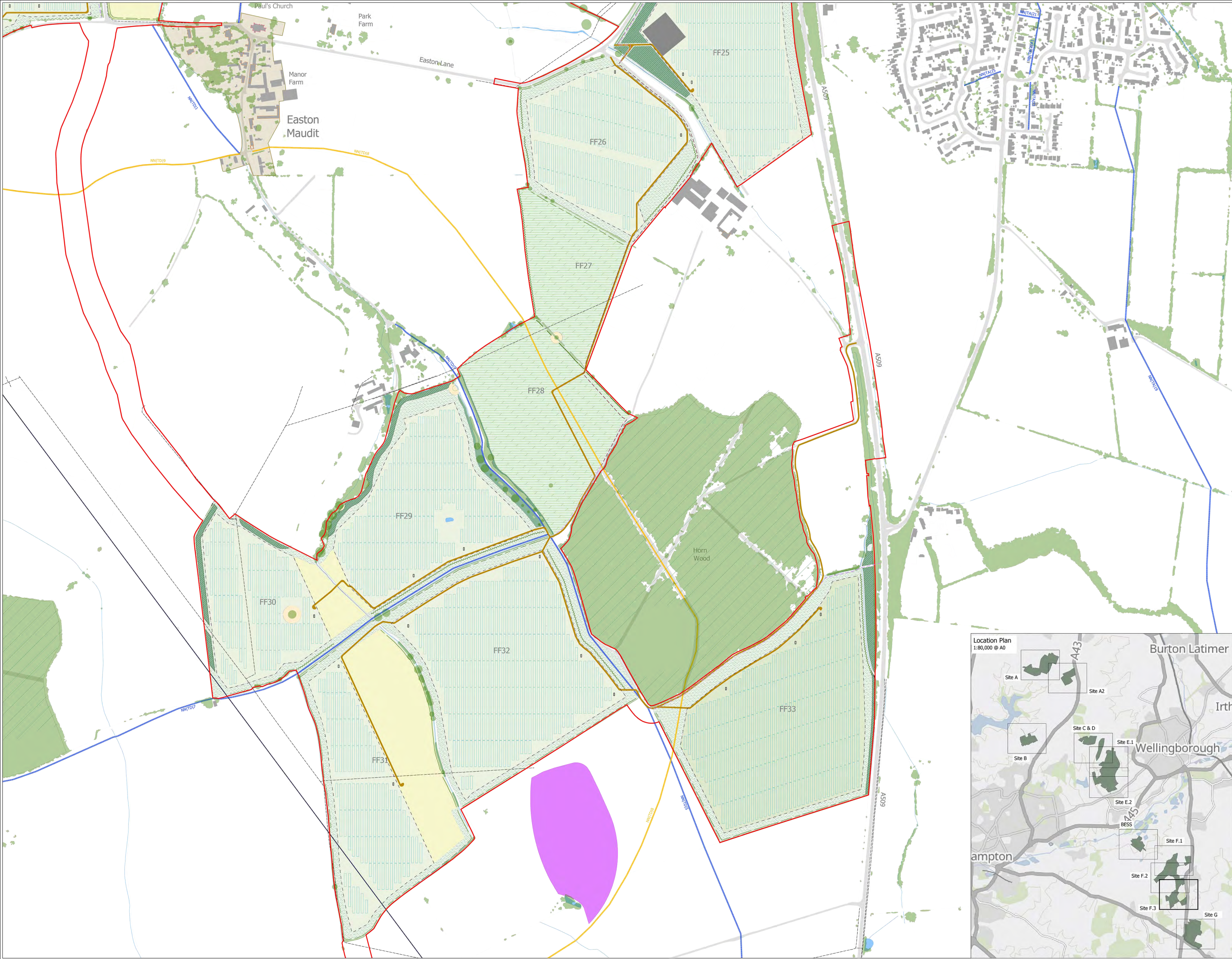

Key

| | |
|--|--|
| | Area For Solar Panels And Associated Development |
| | Existing Vegetation |
| | Existing Ditch Verge |
| | Existing Footpath |
| | Existing Bridleway |
| | Existing Byway Open To All Traffic |
| | Existing Restricted Byways |
| | Existing Buildings |
| | Existing Listed Buildings |
| | Existing Utilities |
| | Existing Vegetation To Be Retained And Enhanced |
| | Proposed Meadow Creation (Beneath Panels) |
| | Proposed Tussock Grassland Margins |
| | Proposed Damp Grassland |
| | Proposed Ground Nesting Bird Mitigation - Set Aside |
| | Proposed Ground Nesting Bird Mitigation - Continued Arable Land |
| | Proposed Diverse Wildflower Meadow |
| | Proposed Low Density Scrub |
| | Proposed Native Woodland Copse/ Shelter Belt (Scrub And Tree Planting) |
| | Dense Linear Tree Planting (Without Scrub Planting) |
| | Native Tree and Scrub Planting - Instant Screening |
| | Native Scrub Planting With Scattered Trees |
| | Proposed River Corridor Planting For Ecology |
| | Proposed River Corridor Planting For Flooding |
| | Proposed River Corridor Planting For Instant Screening |
| | Proposed Indicative Locations For Posts |
| | Potential Location For Proposed Cluster Of Water Scrapes |
| | Existing Hedge To Be Reinforced With Irregularly Spaced Native Tree Planting |
| | Existing Hedge To Be Reinforced With Densely Spaced Native Tree Planting |
| | Existing Hedge To Be Reinforced With Densely Spaced Native Tree Planting - Instant Screening |
| | Proposed Native Species Rich Hedgerow With Irregularly Spaced Native Hedgerow Trees |
| | Proposed Secondary Native Species Rich Hedgerow With Densely Spaced Native Hedgerow Trees |
| | Proposed Solar Arrays |
| | Proposed Fenceline |
| | Proposed Access Tracks |
| | Proposed Inverters |
| | Proposed Substation |
| | Proposed Battery Energy Storage Systems |
| | Proposed Permissive Path For Pedestrians |
| | Proposed Permissive Path For Pedestrians And Horse Riders |
| | Existing Vegetation To Be Removed |

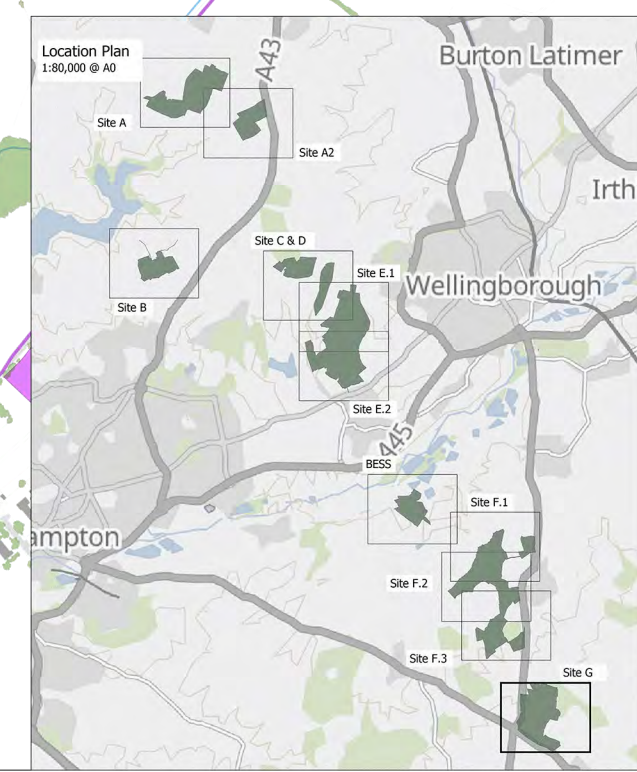
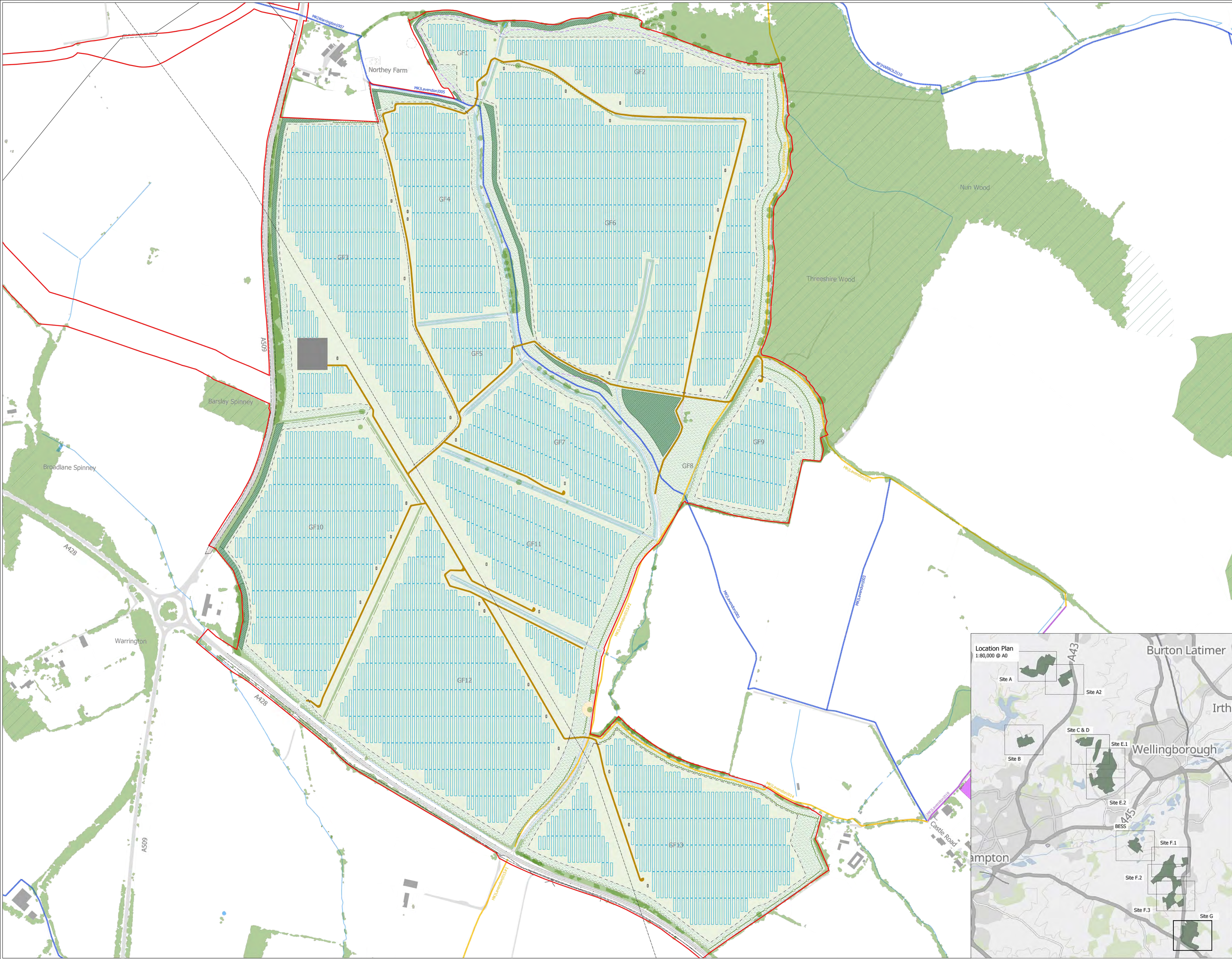

Key

- Area For Solar Panels And Associated Development
- Existing
 - Existing Vegetation
 - Existing Ditch Verge
 - Existing Footpath
 - Existing Brideway
 - Existing Byway Open To All Traffic
 - Existing Restricted Byways
 - Existing Buildings
 - Existing Listed Buildings
 - Existing Utilities
- Proposed
 - Existing Vegetation To Be Retained And Enhanced
 - Proposed Meadow Creation (Beneath Panels)
 - Proposed Tussock Grassland Margins
 - Proposed Damp Grassland
 - Proposed Ground Nesting Bird Mitigation - Set Aside
 - Proposed Ground Nesting Bird Mitigation - Continued Arable Land
 - Proposed Diverse Willflower Meadow
 - Proposed Low Density Scrub
 - Proposed Native Woodland Coppes/Shelter Belt (Scrub And Tree Planting)
 - Dense Linear Tree Planting (Without Scrub Planting)
 - Native Tree and Scrub Planting - Instant Screening
 - Native Scrub Planting With Scattered Trees
 - Proposed River Corridor Planting For Ecology
 - Proposed River Corridor Planting For Flooding
 - Proposed River Corridor Planting For Instant Screening
 - Proposed Indicative Locations For Ponds
 - Potential Location For Proposed Cluster Of Water Scrapes
 - Existing Hedge To Be Reinforced With Irregularly Spaced Native Tree Planting
 - Existing Hedge To Be Reinforced With Densely Spaced Native Tree Planting
 - Existing Hedge To Be Reinforced With Densely Spaced Native Tree Planting - Instant Screening
 - Proposed Native Species Rich Hedgerow With Irregularly Spaced Native Hedgerow Trees
 - Proposed Secondary Native Species Rich Hedgerow With Densely Spaced Native Hedgerow Trees
 - Proposed Solar Arrays
 - Proposed Fencing
 - Proposed Access Tracks
 - Proposed Inverters
 - Proposed Substation
 - Proposed Battery Energy Storage Systems
 - Proposed Permissive Path For Pedestrians
 - Proposed Permissive Path For Pedestrians And Horse Riders
 - Existing Vegetation To Be Removed
 - Proposed Acoustic Barrier North Of BESS 2 Comprising Bund With Scattered Scrub And Trees And Acoustic Barrier

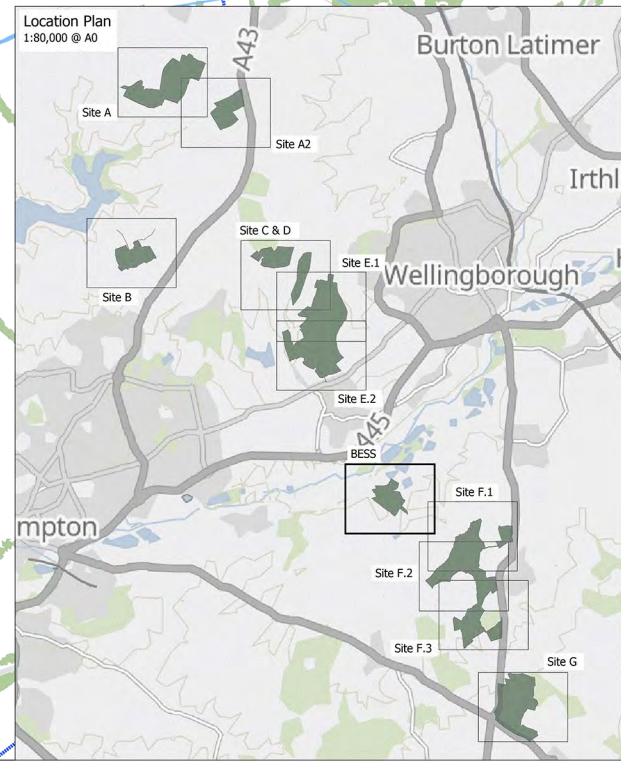
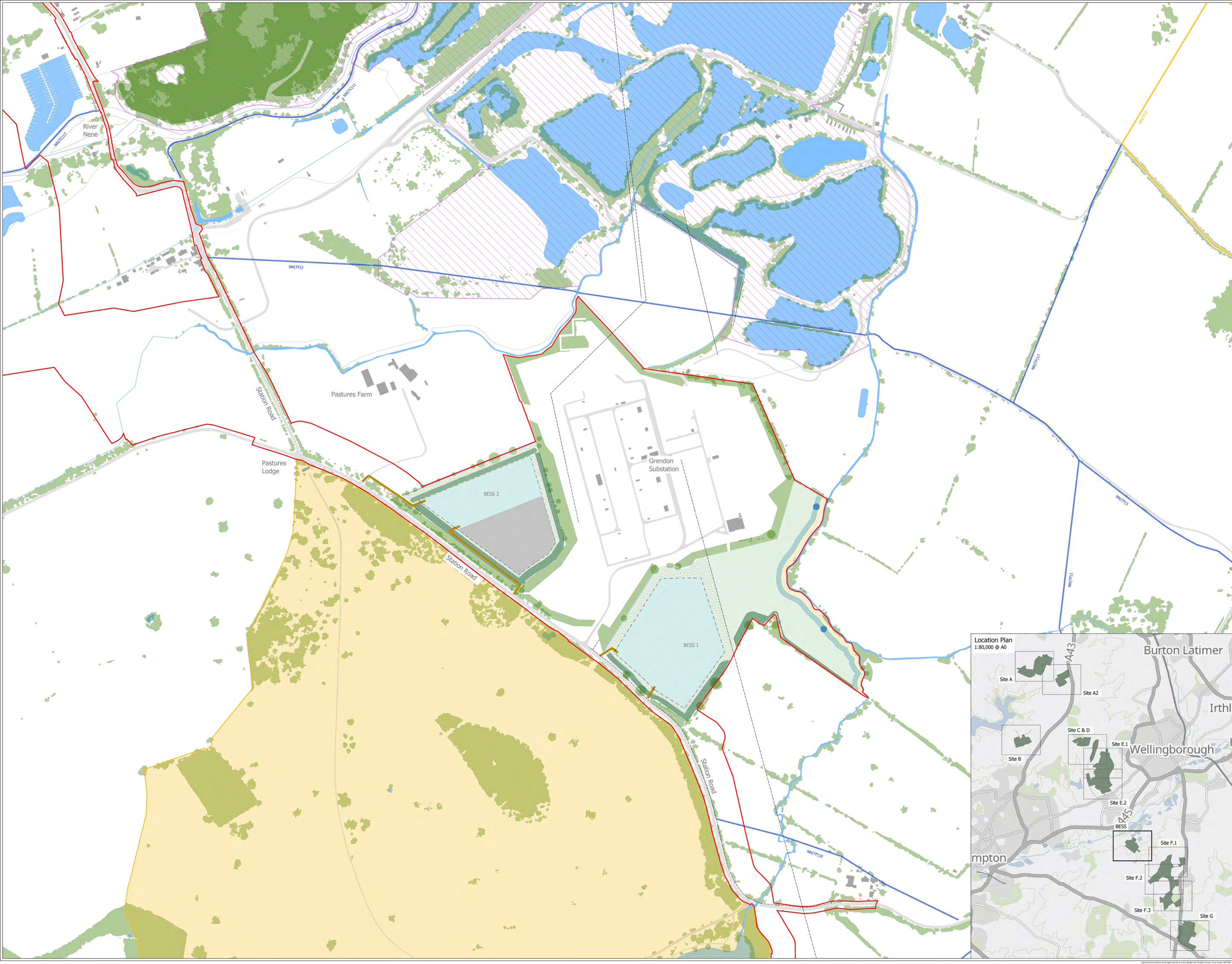

APPENDIX 1.3: SURVEY EQUIPMENT

SPECTRA
GEOSPATIAL

SP80



**THE MOST CONNECTED
GNSS RECEIVER**

spectrageospatial.com

SPECTRA
GEOSPATIAL

SP80

GNSS CHARACTERISTICS

- 240 GNSS channels
 - GPS L1CA, L1P(Y), L2C, L2P(Y), L5
 - GLONASS L1CA, L1P, L2CA, L2P, L5
 - Galileo (Phase II) E1B, E2
 - Galileo E1, E5a, E5b
 - QZSS L1CA, L1-SAIF, L1C, L2C, L5
 - SBAS L1CA, L5 (WAAS, EGNOS, MSAS, GAGAN, SDCM)
 - IRNSS L5
- Support for Trimble RTX™ real-time correction services
- Patented Z-Bias technology for optimal GNSS performance
- Full utilization of signals from all 6 GNSS systems (GPS, GLONASS, Galileo, QZSS and SBAS)
- Enhanced GNSS-swaive algorithms: fully-independent, GNSS signal tracking and optimal data processing, including GPS-only, GLONASS-only or Galileo-only solution (Autonomous to full RTK)
- Fast Search engine for quick acquisition and re-acquisition of GNSS signals
- Patented SBAS ranging for using SBAS code & carrier observations and orbits in RTK processing
- Patented Strobe™ Controller for reduced GNSS multi-path output
- Up to (20 Hz) real-time raw data (code & carrier) and position output
- Supported data formats: ATOM, CHR, CHR+, RTCM 2.1, 2.2, 2.3, 3.0, 3.1 and 3.2 (including MSM, CMR and sCMR (raw only))
- NMEA 0183 messages output

REAL-TIME ACCURACY (RMS)⁽¹⁾⁽²⁾

- SBAS (WAAS/EGNOS/MSAS/GAGAN)
 - Horizontal: < 90 cm
 - Vertical: < 85 cm
- Real-Time DGPS position
 - Horizontal: 25 cm ± 1 ppm
 - Vertical: 50 cm ± 1 ppm
- Real-Time Kinematic Position (RTK)
 - Horizontal: 8 mm ± 1 ppm
 - Vertical: 15 mm ± 1 ppm

Network RTK (N)

- Horizontal: 8 mm ± 0.5 ppm
- Vertical: 15 mm ± 0.5 ppm

REAL-TIME PERFORMANCE

- Instant-RTK Initialization
 - Typically 2 sec for baselines < 20 km
 - Up to 99.9% reliability
- RTK Initialization range: over 40 km

POST-PROCESSING ACCURACY (RMS)⁽¹⁾⁽²⁾

- Static & Fast Static
 - Horizontal: 3 mm ± 0.5 ppm
 - Vertical: 5 mm ± 0.5 ppm
- High-Precision Static⁽³⁾
 - Horizontal: 3 mm ± 0.1 ppm
 - Vertical: 3.5 mm ± 0.4 ppm

TRIMBLE RTX INITIALIZATION⁽³⁾⁽³⁾⁽³⁾

- Horizontal (RMS)
- Initialization
- GNSS

CENTERPOINT® RTX <4 cm <30 mins, <5 mins E1 + E2

DATA LOGGING CHARACTERISTICS

- Recording Interval
 - 0.05 - 999 seconds

PHYSICAL CHARACTERISTICS

- Size
 - 22.2 x 18.4 x 7.5 cm (8.7 x 7.3 x 3.0 in)
- Weight
 - 1.7 kg (2.57 lb)

User Interface

- Graphical PMOLED display
- WEB UI (accessible via WiFi) for easy configuration, operation, status, and data transfer

I/O Interface

- RS232 serial link
- USB 2.0/UART
- Bluetooth 2.1 + EDR
- WiFi (802.11 b/g/n)
- 3.581 quad-band GSM (850/900/1800/1900 MHz) / pentaband UHF-TS module (800/850/900/1800/2100 MHz)

Memory

- 2 GB internal memory NAND Flash (1.5 GB user data)
- Over a year of 15 sec. raw GNSS data from 7+ satellites
- SD/SDHC internal memory card (up to 32GB)

Operation

- RTK rover & base
- RTK network rover: VRS, FKP, MAC
- RTSP, Direct IP
- CSD mode
- Post-processing
- RTK bridge
- UHF repeater
- UHF networking
- Trimble RTX (collator/IP)

Environmental Characteristics

- Operating temperature: -40° to +85°C (-40° to +193°F)⁽⁴⁾
- Storage temperature: -40° to +85°C (-40° to +193°F)⁽⁵⁾
- Humidity: 100% condensing
- IP67 waterproof, sealed against sand and dust
- Drop: 2m pole drop on concrete
- Shock: ETS300 D8
- Vibration: MIL-STD-883C

Power Characteristics

- 2 Li-Ion hot-swappable batteries, 36.5 Wh (2 x 7.4 V, 2600 mAh)
- Battery life time (See battery): 10 hrs. (GNSS On and GSM or UHF Rx On)
- External DC power: 8-28 V

Standard System Components

- SP80 receiver
- 2 Li-Ion batteries
- Dual battery charger, power supply and international power cord kit
- Tape measure (3.6 m / 12 ft)
- 7 m pole extension
- USB to mini-USB cable
- Hard case
- 2 year warranty

Optional System Components

- SP80 UHF Kit (410-430 MHz 2W 1Rx)
- SP80 Field Power Kit
- SP80 Office Power Kit
- Data collectors
 - Ranger S
 - T4
 - MobileMapper 50
- Field software
 - Survey Pro
 - FAST Survey
 - Survey Mobile (Android)
- SP80s control app for 3rd party devices (Android)

Field software

- Survey Pro
- FAST Survey
- Survey Mobile (Android)

SP80s control app for 3rd party devices (Android)

- Ranger S
- T4
- MobileMapper 50

Field software

- Survey Pro
- FAST Survey
- Survey Mobile (Android)

SP80s control app for 3rd party devices (Android)

- Ranger S
- T4
- MobileMapper 50

Field software

- Survey Pro
- FAST Survey
- Survey Mobile (Android)

SP80s control app for 3rd party devices (Android)

- Ranger S
- T4
- MobileMapper 50

Field software

- Survey Pro
- FAST Survey
- Survey Mobile (Android)

SP80s control app for 3rd party devices (Android)

- Ranger S
- T4
- MobileMapper 50

Field software

- Survey Pro
- FAST Survey
- Survey Mobile (Android)

SP80s control app for 3rd party devices (Android)

- Ranger S
- T4
- MobileMapper 50

Field software

- Survey Pro
- FAST Survey
- Survey Mobile (Android)

SP80s control app for 3rd party devices (Android)

- Ranger S
- T4
- MobileMapper 50

Field software

- Survey Pro
- FAST Survey
- Survey Mobile (Android)

SP80s control app for 3rd party devices (Android)

- Ranger S
- T4
- MobileMapper 50

Field software

- Survey Pro
- FAST Survey
- Survey Mobile (Android)

SP80s control app for 3rd party devices (Android)

- Ranger S
- T4
- MobileMapper 50

Field software

- Survey Pro
- FAST Survey
- Survey Mobile (Android)

SP80s control app for 3rd party devices (Android)

- Ranger S
- T4
- MobileMapper 50

CONTACT INFORMATION:

Americas
10398 Westmoor Drive
Westminster, CO 80021 • USA
+1-720-587-6700 Phone
888-477-7518 (Toll Free in USA)

Europe, Middle East and Africa
Rue Thomas Edison
ZAC de la Fleurie - CS 60433
44476 Courcouronnes (Nantes) • FRANCE
+33-402-29-09-39-00 Phone

Asia-Pacific
50 Manne Parade Road
#22-06, Parkway Parade
Singapore 449288 • SINGAPORE
+65-6348-2212 Phone

Please visit spectrageospatial.com for the latest product information and to locate your nearest distributor. Specifications and descriptions are subject to change without notice.

APPENDIX 1.3: SURVEY EQUIPMENT

SP80 GNSS RECEIVER

The Spectra Geospatial SP80 is a next generation GNSS receiver that combines decades of GNSS RTK technology with revolutionary new GNSS processing. Featuring the new 240-channel “6G” chipset combined with the patented Z-Blade technology, the SP80 system is optimized for tracking and processing signals from all GNSS constellations in challenging environments.

As the most connected GNSS receiver in the industry, the SP80 offers a unique combination of integrated 3.5G cellular, Wi-Fi and UHF communications with SMS, email and anti-theft technology.

These powerful capabilities, packaged in an ultra-rugged housing and patented antenna design with unlimited operation time (hot-swappable batteries), make SP80 an extremely versatile turnkey solution.



KEY FEATURES

- Patented Z-Blade technology
- 240-channel 6G ASIC
- Hot-swappable batteries
- Internal TRx UHF radio
- 3.5G cellular modem
- Built-in WiFi communication
- SMS and e-mail alerts
- Anti-theft technology
- Backup RTK
- RTK Bridge
- eLevel technology
- Trimble RTX correction services



Patented inside-the-rod mounted UHF antenna design

UNIQUE 6G GNSS-CENTRIC TECHNOLOGY

Patented Z-Blade processing technology running on a next generation Spectra Geospatial 240-channel 6G ASIC fully utilizes all 6 GNSS systems: GPS, GLONASS, BeiDou, Galileo, QZSS and SBAS. Unlike GPS-centric technology which requires a minimum number of GPS satellites for GNSS processing, Z-Blades unique GNSS-centric capability optimally combines GNSS signals without dependency on any specific GNSS system; this allows SP80 to operate in GPS-only, GLONASS-only or BeiDou-only mode if needed. In addition, SP80 supports the recently approved RTCM 3.2 Multiple Signal Messages (MSM), a standardized definition for broadcasting all GNSS signals from space, regardless of their constellation. This protects the surveyor's investment well into the future by providing superior performance and improved productivity as new signals become available.

SMS AND EMAIL MESSAGING

SP80 has a unique combination of communication technologies including an integrated 3.5G GSM/UMTS modem, Bluetooth and Wi-Fi connectivity, and optional internal UHF transmit radio. The cellular modem may be used for SMS (text message) and e-mail alerts as well as regular Internet or VRS connectivity. SMS (text messages) can be used to monitor and configure the receiver. Likewise, SP80 can use all available RTK correction sources and connect to the Internet from the field using WiFi hotspots, where available. The internal UHF transmit/receive radio allows for quick and easy setup as a local base station. This saves time and increases the surveyor's efficiency.

ANTI-THEFT PROTECTION

A unique anti-theft technology secures SP80 when installed as a field base station in remote or public places and can detect if the product is disturbed, moved or stolen. This technology allows the surveyor to lock the device to a specific location and make it unusable if the device is moved elsewhere. In this case, SP80 will generate an audio alert and show an alert message on its display. Furthermore, a SMS or e-mail will be sent to the surveyor's mobile phone or computer and provides the receiver's current coordinates allowing tracking of its position and facilitating recovery of the receiver. SP80's anti-theft technology provides surveyors with remote security and peace of mind.

TRIMBLE RTX CAPABLE

Trimble RTX correction services offer a wide range of accuracy requirements ranging from better than 4 cm accuracies, up to sub-meter accuracies, without the need of an RTK base station. Trimble RTX is available for the SP80 GNSS receiver via cellular/IP delivery. The premium service, CenterPoint® RTX is the most accurate satellite-delivered correction service available today. With the SP80 GNSS receiver and a Trimble RTX correction, achieve high-accuracy positioning nearly anywhere in the world.

THE MOST POWERFUL TOOL FOR RELIABLE FIELD USE

The SP80's rugged housing, created by Spectra Geospatial's engineering design lab in Germany, incorporates a host of practical innovations. Dual hot-swappable batteries can be easily exchanged in the field as a one hand operation for an interruption-free working day, ensuring surveyors remain productive until the job is done. The impact-resistant glass-fiber reinforced casing, designed to withstand 2m pole drops and waterproof to IP67, ensures that SP80 can handle the toughest outdoor conditions. The patented UHF antenna, set inside the rugged carbon fiber rod, extends the range of RTK radio performance at the same time as armoring protection. The sunlight-readable display offers instant access to key information like the number of satellites, RTK status, battery charge and available memory. With eLevel technology, the user is able to focus in one place when leveling and measuring as well as automatically store measurements when the receiver is level. These powerful design features combine to make SP80 the most capable, most reliable GNSS receiver, backed by a comprehensive standard 2 year warranty.



THE SPECTRA GEOSPATIAL EXPERIENCE

With the most advanced and rugged field data collectors from Spectra Geospatial, surveyors get maximum productivity and reliability every day. Spectra Geospatial Survey Pro or FAST Survey software is specifically tailored for the SP80 GNSS receiver providing easy-to-use, yet powerful GNSS workflows, letting the surveyor concentrate on getting the job done. Spectra Geospatial Survey Office Software provides a complete office suite for post-processing GNSS data and adjusting survey data, as well as exporting the processed results directly back to the field or to engineering design software packages. Combined with Spectra Geospatial field and office software, SP80 is a very powerful and complete solution.

APPENDIX 1.3: SURVEY EQUIPMENT

TOUGHPAD FZ-G1

Panasonic recommends Windows.

| | | | | | | | | | | | | | | | |
|--|---|-------------------|--------|------|--------|--------------------|------------------|-------------------------------------|-------------|----------------------------|-------|--------------------------------------|-------|--|-------|
| SOFTWARE | <ul style="list-style-type: none"> Windows 10 Pro 64 bit Panasonic Utilities (including Dashboard, Recovery Partition) | | | | | | | | | | | | | | |
| DURABILITY | <ul style="list-style-type: none"> MIL-STD-810G certified (4' drop, shock, vibration, rain, dust, sand, altitude, freeze/thaw, high/low temperature, temperature shock, humidity, explosive atmosphere) IP65 certified sealed all-weather design Optional class I division 2, groups ABCD certified model Solid state drive heater Magnesium alloy chassis encased with ABS and elastomer corner guards Optional hand strap or rotating hand strap Port covers Raised bezel for LCD impact protection Pre-installed replaceable screen film for LCD protection | | | | | | | | | | | | | | |
| CPU | <ul style="list-style-type: none"> Intel® Core™ i5-6300U vPro™ Processor ~ 2.4 GHz up to 3.0 GHz with Intel® Turbo Boost Technology Intel Smart Cache 3MB | | | | | | | | | | | | | | |
| STORAGE & MEMORY | <ul style="list-style-type: none"> 8GB DDR3L SDRAM^{1,5} 256GB solid state drive (SSD) with heater^{1,5} Optional 512GB ~ up to 64GB additional storage with optional microSDXC card slot | | | | | | | | | | | | | | |
| DISPLAY | <ul style="list-style-type: none"> 10.1" WUXGA 1920 x 1200 with LED backlighting 10-point capacitive multi touch + Waterproof Digitizer pen daylight-readable screen ~ 2-800 nit IPS display with direct bonding Anti-reflective and anti-glare screen treatments Ambient light sensor, digital compass, gyro and acceleration sensors Automatic screen rotation Intel® HD Graphics 520 (Built-in CPU) video controller Concealed mode (configurable) | | | | | | | | | | | | | | |
| AUDIO | <ul style="list-style-type: none"> Integrated microphone Realtek high-definition audio Integrated speaker On-screen and button volume and mute controls | | | | | | | | | | | | | | |
| KEYBOARD & INPUT | <ul style="list-style-type: none"> 10-point gloved multi touch + digitizer screen Supports bare-hand touch and gestures and electronic waterproof stylus pen Supports glove mode and wet-touch mode 7 tablet buttons (2 user-definable) Integrated stylus holder On-screen QWERTY keyboard | | | | | | | | | | | | | | |
| CAMERAS | <ul style="list-style-type: none"> 720p webcam with mic 8MP rear camera with autofocus and LED light | | | | | | | | | | | | | | |
| EXPANSION | <ul style="list-style-type: none"> Optional microSDXC3 | | | | | | | | | | | | | | |
| INTERFACE | <table border="0"> <tr> <td>Docking connector</td> <td>24-pin</td> </tr> <tr> <td>HDMI</td> <td>Type A</td> </tr> <tr> <td>Headphones/speaker</td> <td>Mini-jack stereo</td> </tr> <tr> <td>Optional Serial Dongle¹</td> <td>D-sub 9-pin</td> </tr> <tr> <td>USB 3.0 (x 1)²</td> <td>4-pin</td> </tr> <tr> <td>Optional second USB 2.0²</td> <td>4-pin</td> </tr> <tr> <td>Optional 10/100/1000 Ethernet³</td> <td>RJ-45</td> </tr> </table> | Docking connector | 24-pin | HDMI | Type A | Headphones/speaker | Mini-jack stereo | Optional Serial Dongle ¹ | D-sub 9-pin | USB 3.0 (x 1) ² | 4-pin | Optional second USB 2.0 ² | 4-pin | Optional 10/100/1000 Ethernet ³ | RJ-45 |
| Docking connector | 24-pin | | | | | | | | | | | | | | |
| HDMI | Type A | | | | | | | | | | | | | | |
| Headphones/speaker | Mini-jack stereo | | | | | | | | | | | | | | |
| Optional Serial Dongle ¹ | D-sub 9-pin | | | | | | | | | | | | | | |
| USB 3.0 (x 1) ² | 4-pin | | | | | | | | | | | | | | |
| Optional second USB 2.0 ² | 4-pin | | | | | | | | | | | | | | |
| Optional 10/100/1000 Ethernet ³ | RJ-45 | | | | | | | | | | | | | | |
| WIRELESS | <ul style="list-style-type: none"> Optional integrated 4G LTE multi carrier mobile broadband with satellite GPS Optional GPS (u-blox NEO M8N)⁴ Intel® Dual Band Wireless-AC 8260 (IEEE802.11a/b/g/n/ac) Bluetooth v4.1, Classic mode/Low Energy mode, Class 1 (Windows 10 pro 64-bit) Security <ul style="list-style-type: none"> Authentication: LEAP, WPA, 802.1x, EAP-TLS, EAP-FAST, PEAP Encryption: TKIP, TKIP, 128-bit and 64-bit WEP, Hardware AES Dual high-gain antenna pass-through | | | | | | | | | | | | | | |
| POWER SUPPLY | <ul style="list-style-type: none"> Li-ion battery pack: <ul style="list-style-type: none"> Standard battery: Li-ion 11.1 V, 4200 mAh (typ.), 4080 mAh (min.) Optional long life battery⁵: Li-ion 10.8V, 9300mAh(1typ.), 8700mAh (min.) Battery operation⁶: <ul style="list-style-type: none"> Standard battery: 14 hours Optional long life battery⁵: 28 hours Battery charging time⁶: <ul style="list-style-type: none"> Standard battery: 2.5 hours off, 3 hours on Optional long life battery⁵: 3 hours off, 4 hours on Optional bridge battery⁷ (1 minute swap time) | | | | | | | | | | | | | | |
| POWER MANAGEMENT | <ul style="list-style-type: none"> Suspend/Resume Function, Hibernation, Standby | | | | | | | | | | | | | | |
| SECURITY FEATURES | <ul style="list-style-type: none"> Password Security: Supervisor, User, Hard Disk Lock Kensington cable lock slot Trusted platform module (TPM) security chip v2.0¹¹ CompuTrace[®] theft protection agent in BIOS⁸ Optional Insertable SmartCard reader⁹ Optional Contactless SmartCard/HF RFID reader⁹ ISO 15693 and 14443 A/B compliant | | | | | | | | | | | | | | |

| | | | | | | | | | | | | | | | | | | | | | | | | | | | | | | | | | | | | | | | | | | | | | | | | | | | | | | | |
|--|--|----------------------|-------------|-----------------------|-------------|-------------------------------------|-----------|--|-------------------|-------------------------------|-----------------|----------------------------|-------------|-----------------------|-------------|---|-------------|------------------------------|-------------|-----------------------|------------|--|-----------------|---|-------------|-------------------------------------|-----------------|---------------------------|-------------|----------------|-------------|---------------------------------|--|------------------|----------------|--------------------------------|----------------|-----------------------------------|--|------------------|----------------|--------------------------------|------------------|--------------------|--|-----------|------------------|--------|------------------|--------------------------------------|--------------|--------|------------|---------------------------|------------|
| WARRANTY | <ul style="list-style-type: none"> 3-year limited warranty, parts and labor | | | | | | | | | | | | | | | | | | | | | | | | | | | | | | | | | | | | | | | | | | | | | | | | | | | | | | |
| DIMENSIONS & WEIGHT¹⁰ | <ul style="list-style-type: none"> 10.6" (L) x 7.4" (W) x 0.8" (H) 2.4 lbs. (standard battery) 3.0 lbs. (optional long life battery)¹¹ | | | | | | | | | | | | | | | | | | | | | | | | | | | | | | | | | | | | | | | | | | | | | | | | | | | | | | |
| INTEGRATED OPTIONS¹² | <ul style="list-style-type: none"> 4G LTE multi carrier mobile broadband with satellite GPS Choice of 1D/2D barcode reader (EA11 or EA21), GPS, Serial Dongle, Ethernet, MicroSDXC or second USB 2.0 port¹ Choice of bridge battery, magstripe reader, insertable SmartCard reader, insertable SmartCard reader with bridge battery, contactless SmartCard/RFID HF reader or UHF 900MHz RFID reader (EPC Gen 2)¹² | | | | | | | | | | | | | | | | | | | | | | | | | | | | | | | | | | | | | | | | | | | | | | | | | | | | | | |
| ACCESSORIES¹³ | <table border="0"> <tr> <td>AC Adapter (3-prong)</td> <td>CF-AA6413CM</td> </tr> <tr> <td>Standard Battery Pack</td> <td>FZ-VSU864ZU</td> </tr> <tr> <td>Long Life Battery Pack⁵</td> <td>FZ-VSU88U</td> </tr> <tr> <td>Long Life Battery Bundle (includes rotating hand strap and corner guard set)</td> <td>FZ-BNDL01115T1CG4</td> </tr> <tr> <td>Single Battery Charger Bundle</td> <td>FZ-BNDL01BATCHR</td> </tr> <tr> <td>LIND 3-Bay Battery Charger</td> <td>FZ-LND3BAG1</td> </tr> <tr> <td>LIND Car Adapter 120W</td> <td>CF-LNDCC120</td> </tr> <tr> <td>LIND Car/AC Adapter 90W (with USB port)</td> <td>CF-LNDACC90</td> </tr> <tr> <td>LIND Car Adapter 90W MIL-STD</td> <td>CF-LNDMLC90</td> </tr> <tr> <td>Tall Corner Guard Set</td> <td>FZ-WCGG111</td> </tr> <tr> <td>Rotating Hand Strap and Tall Corner Guard Set Bundle</td> <td>FZ-BNDL01ST1CG4</td> </tr> <tr> <td>ToughMate G1 Always-On Case (with hand strap)</td> <td>TBCG1AGNL-P</td> </tr> <tr> <td>ToughMate G1 Professional Portfolio</td> <td>TBCG1PFLD-BLK-P</td> </tr> <tr> <td>ToughMate G1 X Hand Strap</td> <td>TBCG1XSTP-P</td> </tr> <tr> <td>Desktop Cradle</td> <td>FZ-VEBG11AU</td> </tr> <tr> <td>Vehicle Docks (no pass-through)</td> <td></td> </tr> <tr> <td>- Gamber-Johnson</td> <td>7160-0486-00-P</td> </tr> <tr> <td>- Havis with LIND power supply</td> <td>CF-H-PAN-702-P</td> </tr> <tr> <td>Vehicle Docks (dual pass-through)</td> <td></td> </tr> <tr> <td>- Gamber-Johnson</td> <td>7160-0486-02-P</td> </tr> <tr> <td>- Havis with LIND power supply</td> <td>CF-H-PAN-702-2-P</td> </tr> <tr> <td>Cradlepoint Router</td> <td></td> </tr> <tr> <td>- Verizon</td> <td>CP-IBR1100LPE-VZ</td> </tr> <tr> <td>- AT&T</td> <td>CP-IBR1100LPE-AT</td> </tr> <tr> <td>Replacement Digitizer Pen Waterproof</td> <td>FZ-VNPG11U-S</td> </tr> <tr> <td>Tether</td> <td>FZ-VNTG11U</td> </tr> <tr> <td>10.1" LCD Protective Film</td> <td>FZ-VFPG11U</td> </tr> </table> | AC Adapter (3-prong) | CF-AA6413CM | Standard Battery Pack | FZ-VSU864ZU | Long Life Battery Pack ⁵ | FZ-VSU88U | Long Life Battery Bundle (includes rotating hand strap and corner guard set) | FZ-BNDL01115T1CG4 | Single Battery Charger Bundle | FZ-BNDL01BATCHR | LIND 3-Bay Battery Charger | FZ-LND3BAG1 | LIND Car Adapter 120W | CF-LNDCC120 | LIND Car/AC Adapter 90W (with USB port) | CF-LNDACC90 | LIND Car Adapter 90W MIL-STD | CF-LNDMLC90 | Tall Corner Guard Set | FZ-WCGG111 | Rotating Hand Strap and Tall Corner Guard Set Bundle | FZ-BNDL01ST1CG4 | ToughMate G1 Always-On Case (with hand strap) | TBCG1AGNL-P | ToughMate G1 Professional Portfolio | TBCG1PFLD-BLK-P | ToughMate G1 X Hand Strap | TBCG1XSTP-P | Desktop Cradle | FZ-VEBG11AU | Vehicle Docks (no pass-through) | | - Gamber-Johnson | 7160-0486-00-P | - Havis with LIND power supply | CF-H-PAN-702-P | Vehicle Docks (dual pass-through) | | - Gamber-Johnson | 7160-0486-02-P | - Havis with LIND power supply | CF-H-PAN-702-2-P | Cradlepoint Router | | - Verizon | CP-IBR1100LPE-VZ | - AT&T | CP-IBR1100LPE-AT | Replacement Digitizer Pen Waterproof | FZ-VNPG11U-S | Tether | FZ-VNTG11U | 10.1" LCD Protective Film | FZ-VFPG11U |
| AC Adapter (3-prong) | CF-AA6413CM | | | | | | | | | | | | | | | | | | | | | | | | | | | | | | | | | | | | | | | | | | | | | | | | | | | | | | |
| Standard Battery Pack | FZ-VSU864ZU | | | | | | | | | | | | | | | | | | | | | | | | | | | | | | | | | | | | | | | | | | | | | | | | | | | | | | |
| Long Life Battery Pack ⁵ | FZ-VSU88U | | | | | | | | | | | | | | | | | | | | | | | | | | | | | | | | | | | | | | | | | | | | | | | | | | | | | | |
| Long Life Battery Bundle (includes rotating hand strap and corner guard set) | FZ-BNDL01115T1CG4 | | | | | | | | | | | | | | | | | | | | | | | | | | | | | | | | | | | | | | | | | | | | | | | | | | | | | | |
| Single Battery Charger Bundle | FZ-BNDL01BATCHR | | | | | | | | | | | | | | | | | | | | | | | | | | | | | | | | | | | | | | | | | | | | | | | | | | | | | | |
| LIND 3-Bay Battery Charger | FZ-LND3BAG1 | | | | | | | | | | | | | | | | | | | | | | | | | | | | | | | | | | | | | | | | | | | | | | | | | | | | | | |
| LIND Car Adapter 120W | CF-LNDCC120 | | | | | | | | | | | | | | | | | | | | | | | | | | | | | | | | | | | | | | | | | | | | | | | | | | | | | | |
| LIND Car/AC Adapter 90W (with USB port) | CF-LNDACC90 | | | | | | | | | | | | | | | | | | | | | | | | | | | | | | | | | | | | | | | | | | | | | | | | | | | | | | |
| LIND Car Adapter 90W MIL-STD | CF-LNDMLC90 | | | | | | | | | | | | | | | | | | | | | | | | | | | | | | | | | | | | | | | | | | | | | | | | | | | | | | |
| Tall Corner Guard Set | FZ-WCGG111 | | | | | | | | | | | | | | | | | | | | | | | | | | | | | | | | | | | | | | | | | | | | | | | | | | | | | | |
| Rotating Hand Strap and Tall Corner Guard Set Bundle | FZ-BNDL01ST1CG4 | | | | | | | | | | | | | | | | | | | | | | | | | | | | | | | | | | | | | | | | | | | | | | | | | | | | | | |
| ToughMate G1 Always-On Case (with hand strap) | TBCG1AGNL-P | | | | | | | | | | | | | | | | | | | | | | | | | | | | | | | | | | | | | | | | | | | | | | | | | | | | | | |
| ToughMate G1 Professional Portfolio | TBCG1PFLD-BLK-P | | | | | | | | | | | | | | | | | | | | | | | | | | | | | | | | | | | | | | | | | | | | | | | | | | | | | | |
| ToughMate G1 X Hand Strap | TBCG1XSTP-P | | | | | | | | | | | | | | | | | | | | | | | | | | | | | | | | | | | | | | | | | | | | | | | | | | | | | | |
| Desktop Cradle | FZ-VEBG11AU | | | | | | | | | | | | | | | | | | | | | | | | | | | | | | | | | | | | | | | | | | | | | | | | | | | | | | |
| Vehicle Docks (no pass-through) | | | | | | | | | | | | | | | | | | | | | | | | | | | | | | | | | | | | | | | | | | | | | | | | | | | | | | | |
| - Gamber-Johnson | 7160-0486-00-P | | | | | | | | | | | | | | | | | | | | | | | | | | | | | | | | | | | | | | | | | | | | | | | | | | | | | | |
| - Havis with LIND power supply | CF-H-PAN-702-P | | | | | | | | | | | | | | | | | | | | | | | | | | | | | | | | | | | | | | | | | | | | | | | | | | | | | | |
| Vehicle Docks (dual pass-through) | | | | | | | | | | | | | | | | | | | | | | | | | | | | | | | | | | | | | | | | | | | | | | | | | | | | | | | |
| - Gamber-Johnson | 7160-0486-02-P | | | | | | | | | | | | | | | | | | | | | | | | | | | | | | | | | | | | | | | | | | | | | | | | | | | | | | |
| - Havis with LIND power supply | CF-H-PAN-702-2-P | | | | | | | | | | | | | | | | | | | | | | | | | | | | | | | | | | | | | | | | | | | | | | | | | | | | | | |
| Cradlepoint Router | | | | | | | | | | | | | | | | | | | | | | | | | | | | | | | | | | | | | | | | | | | | | | | | | | | | | | | |
| - Verizon | CP-IBR1100LPE-VZ | | | | | | | | | | | | | | | | | | | | | | | | | | | | | | | | | | | | | | | | | | | | | | | | | | | | | | |
| - AT&T | CP-IBR1100LPE-AT | | | | | | | | | | | | | | | | | | | | | | | | | | | | | | | | | | | | | | | | | | | | | | | | | | | | | | |
| Replacement Digitizer Pen Waterproof | FZ-VNPG11U-S | | | | | | | | | | | | | | | | | | | | | | | | | | | | | | | | | | | | | | | | | | | | | | | | | | | | | | |
| Tether | FZ-VNTG11U | | | | | | | | | | | | | | | | | | | | | | | | | | | | | | | | | | | | | | | | | | | | | | | | | | | | | | |
| 10.1" LCD Protective Film | FZ-VFPG11U | | | | | | | | | | | | | | | | | | | | | | | | | | | | | | | | | | | | | | | | | | | | | | | | | | | | | | |

Please consult your reseller or Panasonic representative before purchasing.

Caution: Do not expose bare skin to this product when handling this unit in extreme hot or cold environments.

¹ Approximate time. Battery operation and recharge times will vary based on many factors, including screen brightness, applications, features, power management, battery conditioning and other customer preferences.

² Battery testing results from MobileMark 2007.

³ Bridge battery, magstripe reader, insertable SmartCard reader, insertable SmartCard reader with bridge battery, contactless SmartCard reader and UHF RFID reader are mutually exclusive. Please note, USB 3.0 port cannot be accessed when the unit is equipped with the magstripe reader, but optional USB 2.0 port can be accessed.

⁴ GPS, Serial Dongle, Ethernet, MicroSDXC and second USB port are mutually exclusive options.

⁵ 1GB = 1,000,000,000 bytes.

⁶ Total usable memory will be less depending upon actual system configuration.

⁷ The size of the VRAM cannot be set by the user and varies by operating system as well as the size of the RAM.

⁸ Windows 7 max. VRAM is 1555MB.

⁹ Magstripe reader, insertable SmartCard reader, insertable SmartCard reader with bridge battery and UHF RFID reader include full corner guards and rotating hand strap. Bridge battery (without SmartCard reader) includes medium corner guards and rotating hand strap.

¹⁰ Requires software and activation to enable theft protection.

¹¹ Length measurements do not include protrusions. Weight varies with options and digitizer pen.

¹² Accessories and Integrated Options may vary depending on your configuration. Visit the Panasonic website for more accessories and details.

¹³ Hazardous location certifications may not apply to all configurations. Consult your Panasonic representative for availability.

¹⁴ TPM 1.2 available upon request - please contact your reseller or Panasonic representative.



TOUGHPAD



1.800.662.3537

panasonic.com/toughpad/G1

Panasonic is constantly enhancing product specifications and accessories. Specifications subject to change without notice. Trademarks are property of their respective owners. ©2018 Panasonic Corporation of North America. All rights reserved. Toughpad FZ-G1 m3 Spec Sheet_01/18

APPENDIX 1.4: CAMERA EQUIPMENT (CANON 5D MARK IV)



Canon
EOS 5D Mark IV

APPENDIX 1.4: CAMERA EQUIPMENT (SIGMA 50mm f/1.4)



+ Design detail



Incredible resolution ideal for the high-megapixel era. Introducing the new benchmark large-aperture standard lens

In 2008, Sigma released a large diameter standard lens designed for digital SLRs, "SIGMA 50mm F1.4 EX DG HSM". At that time, products for film cameras were prevalent, yet we spent enormous effort to set a new benchmark for the 50mm lens that optimizes the characteristics of digital cameras, such as compensating peripheral brightness, controlling the point images in the corners, and improving the image drawing, not only around the focusing point, but also other areas in the image.

APPENDIX 1.4: CAMERA EQUIPMENT (MANFROTTO 303 SPH)



MANFROTTO
INSTRUCTIONS

303SPH
SPHERICAL "VR" HEAD

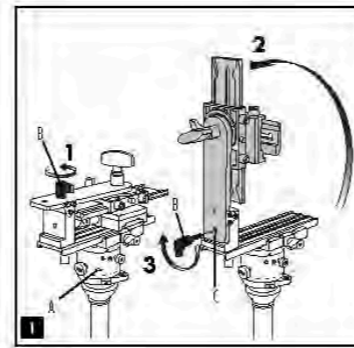

The spherical "VR" head is designed to allow vertical scenes to be created by Computer from a variety of panoramic sequences of digital or digital photographic, when a 40 frames per second camera is used.

- There are 4 requirements to achieve good panoramic sequences:
1. Accurate leveling of the panoramic axis.
 2. A panoramic head that enables you to choose the angle of rotation between one distant and the next.
 3. The ability to position the camera on the "World Point" of the lens (the front lens) is exactly above the panoramic axis of rotation, to eliminate any parallax problems between the near and distant objects in the scene.
 4. An additional rotating axis that enables you to choose panoramic sequences at different vertical angles in order to achieve a complete spherical scene.

The spherical "VR" head comprises three main modules that perform the functions mentioned above in points 2, 3 and 4.

When your tripod has a built-in leveling device (such as the one in the Ball Tripod's 50mm lid ball), you will need to use one of the leveling accessories available from the Manfrotto range to ensure accurate leveling of the head (see point 1).

SET UP 1
Fit the leveling device (not supplied) to the tripod, then fit the "VR" head on the leveling device via knob attachment "A". Completely remove knob "B", rotate the bracket into the vertical position as shown in Fig. 1 and lock it in place by screwing the knob "B" into hole "C".

2

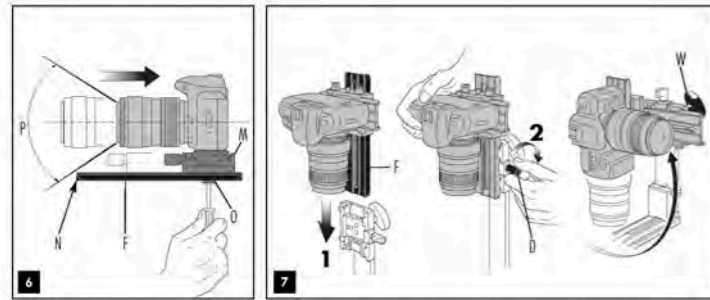

NOTE 4
The position of the housing "M" relative to the long plate "P" will need to be adjusted: loosen screw "O" to slide the housing. The ideal position is with the camera body as far back on the plate as it can go before the front edge "N" of the long plate "P" becomes visible in the camera's field of view "Q".

MOUNT THE CAMERA ON THE HEAD 7
Mount the whole top assembly + camera on the head as shown in figure 7 by sliding the long plate "P" into its housing and locking it by screwing knob "D". Then unscrew knob "B" and move the camera on the vertical plate.

4

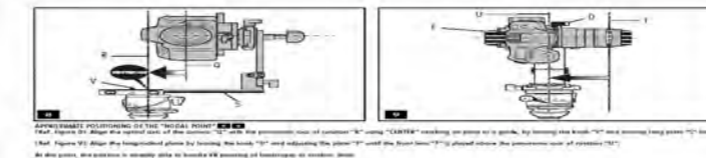

LEVEL THE CAMERA 8
Adjust the camera level by moving the camera on the vertical plate "P" until the bubble level "L" is perfectly horizontal. To do this, loosen knob "E" and rotate the camera on the vertical plate "P".

5

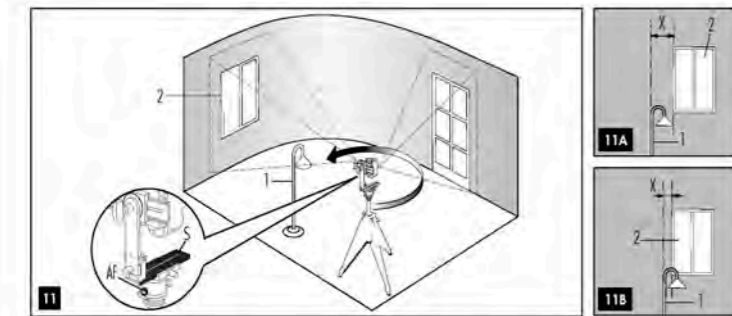

LATERAL POSITIONING 11
Ref. Figure 11: Choose a frame that contains both a near object "1" and a distant object "2" situated along the same horizontal line of vision.
1. (See Figure 11A and 11B): unscrew knob "AF" and move the camera around the panoramic axis so that the two objects are first on the left hand side of the frame, then on the right. Check whether the horizontal gap "X" between the two objects varies in the two frames: the more constant the distance remains, the more accurately the "World Point" has been positioned.
2. For optimum results, make minor adjustments by moving plate "S".

Once the right position is achieved it is VERY USEFUL to measure it by noting the position of the plate "S" on the index on the graduated scale.

7

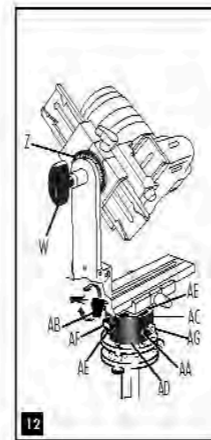

INSTRUCTIONS FOR SPHERICAL PANORAMIC SHOOTING 12
A special panoramic scene is obtained by adding together panoramic sequences taken at different angles from the horizontal. First you will need to choose the number of panoramic sequences you will need to complete the sphere depending on the angle of the lens you will be using.

Before starting with the panoramic sequence, choose the initial vertical angle using the rotator scale "Z" (Fig. 12). Unscrew locking knob "AF" or remove it completely if you are unsecured (it must be used to completely stop rotation when the head is used in non-vertical position, or to avoid any accidental movement of the head in any position).

Decide the number of shots at the angle of rotation between each shot for the first panoramic sequence (see the chart below):

| Angle | 90° | 60° | 45° | 36° | 30° | 24° | 20° | 15° | 10° | 5° |
|----------|-----|-----|-----|-----|-----|-----|-----|-----|-----|----|
| n. shots | 4 | 6 | 8 | 10 | 12 | 15 | 18 | 24 | 36 | 72 |

- Screw knob "AG" into the selected setting hole "AA".
- Release locking lever "AB" and rotate the camera on top plate "AE" to the position of the first shot.
- Hold the camera in position and rotate the central barrel "AC" until the first "click stop" is reached, then lock lever "AB".
- Take the first shot and then rotate the camera to the next "click stop" without releasing "AB" and take the next shot.

Continue the process until the start position is reached.

Once you have completed the first complete panoramic sequence, you can start in the other panoramic sequences needed to cover the sphere: change the vertical angle using knob "AF" and repeat the operations described above for each full sequence.

The lens of the head "AD" has graduated scale markings from 0 to 300° and a reference index "AE" to the central barrel "AC". This is to be used to set angles not on the chart. To use the head in this way, release knob "AG" to disengage the "click stop" driving rotation of central barrel "AC" and use the locking knob "AF" to lock the position during shooting.

NOTE: The angle of the lever on the rotator knob "AB" can be repositioned as required without affecting the lock knob. Pull the lever upwards, rotate as required and release and it will locate in the new position.

8

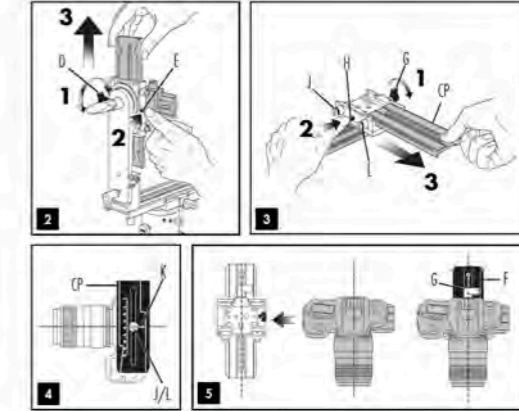

MOUNTING THE CAMERA 3 4 5
Remove the top assembly (Fig. 7) by releasing knob "D". To slide it completely out of the housing, push safety button "E".

Remove camera plate "CP" (Fig. 3) by releasing knob "G". To slide it completely out of the housing, push safety button "H".

You will find two screws attached to the top assembly: screw "I" (Fig. 3) is 1/4 in. "L" is 3/8 in. Depending on your camera tripod attachment, choose the correct screw and use it to fix your camera to plate "CP" (Fig. 4). Use a coin or screwdriver to lock: take care to align the lens with the centre of the plate indicated by letter "K".

Mount the camera on the top assembly as shown in figure 5 by sliding the camera + plate into the housing following the direction shown by the "insert" arrow. Lock in place using knob "G", before locking, take care to align the lens with the long plate "P" - the lens ends must be perfectly above the slot of the plate as shown in figure 5. The angle of the lever on the rotator knob "C" can be repositioned as required without affecting the lock knob. Pull the lever upwards, rotate as required and release and it will locate in the new position.

3

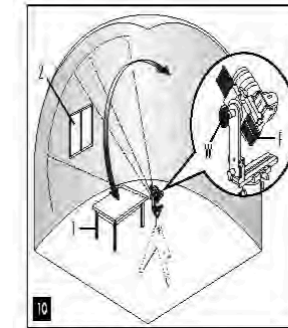

ACTIVE POSITIONING OF THE "WORLD POINT" 10
If the scene being shot contains objects at varying distances from the point where the shot is being taken (near and distant objects), the "World Point" needs to be more accurately positioned to follow (the greater the possible OMT with wider camera).
Note:
- HORIZONTAL POSITIONING
- VERTICAL POSITIONING ONLY WHEN LONGER RANGE POSITION HAS BEEN SET

LONGER RANGE POSITIONING 10
Ref. Figure 10: Choose a frame that contains both a near object "1" and a distant object "2" situated along the same vertical line of vision.
1. (See Figure 10A and 10B): unscrew knob "IC" and move the camera on the vertical plate for bringing the two objects first to the top and then to the bottom of the frame, checking whether the height gap "Y" between the two objects varies in the two frames: the more constant the distance remains, the more accurately the "World Point" has been positioned.
2. For optimum results, make minor adjustments by moving plate "S".

Once the right position is achieved it is VERY USEFUL to measure it by noting the position of the plate "S" on the index on the graduated scale.

1

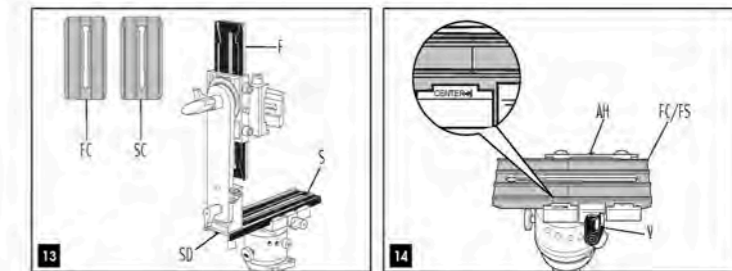

ADDITIONAL PLATES 13
If you have a very compact camera we suggest you fit one of the short plates "SC" (Fig. 13) and "FC" (supplied with this head) instead of the two long plates "P" and "S". In order to reduce space and weight of the system.
To replace the plate "S": unscrew screw "SD" (Fig. 13).
To replace the plate "P", please refer to Fig. 6 and unscrew screw "O".

USE OF THE KIT AS AN OBJECT PANORAMA TURNABLE 14
The head can also be used as a turntable, useful for shooting object panoramas. For this use, loosen knob "H" and push button "AH" to slide the lower plate "S" out of the housing on the panoramic rotation base unit. In place of the long plate and top assembly, mount one of the two shorter plates supplied as a base for your object. The plate housing has a "center" mark to help you position your object accurately above the center of panoramic rotation.

9